



Size: 11.47in x 4.43in x 1.91in (291.3mm x 112.4mm x 48.4mm)

**FEATURES**

- Input Voltage Range of 120~277VAC
- Constant Voltage LED Driver
- RoHS Compliant
- Over Voltage, Over Current, Over Temperature, and Short Circuit Protection
- IP67 Design for Wet Locations

**DESCRIPTION**

The PSLEDR400 series of constant voltage LED drivers offers 400 watts of power in an 11.47" x 4.43" x 1.91" package. This series consists of single output models with an input voltage range of 120~277VAC and an IP67 design for wet locations. Each model in this series is RoHS compliant and is protected against over voltage, over current, over temperature, and short circuit conditions.

**MODEL SELECTION TABLE**

Model Number	Input Voltage Range	Output Voltage	Output Current		OCV	Efficiency			Max. Output Power	Remote Mounting Distance (#14 AWG)
			Min Load	Max Load		@120V	@240V	@277V		
PSLEDR400-24S	120~277VAC	24V	0A	16.5A	25V	91.5%	92%	93%	400W	5ft
PSLEDR400-48S		48V	0A	8.3A	49V	92%	93%	94%	400W	11ft

**SPECIFICATIONS**

All specifications are based on 25°C, Nominal Input Voltage, and Maximum Output Current unless otherwise noted. We reserve the right to change specifications based on technological advances.

SPECIFICATION	TEST CONDITIONS	Min	Typ	Max	Unit
<b>INPUT SPECIFICATIONS</b>					
Input Voltage Range	±10%	120		277	VAC
Frequency			50/60		Hz
Inrush Current	@277V		75		A
Input Current	@120V			3.95	A
	@240V			2.02	
	@277V			1.75	
Power Factor	Under 120~277VAC input, 80~100% load condition, all output voltages	0.9			
THD	Under 120~277VAC input, 80~100% load condition, all output voltages			20	%
No Load Power Consumption				4	W
<b>OUTPUT SPECIFICATIONS</b>					
Output Voltage		See Table			
Line Regulation			±1		%
Load Regulation			±2		%
Output Tolerance	@Full Load Condition		±5		%
Output Power		See Table			
Output Current		See Table			
Ripple & Noise (pk-pk)				3	%
Turn-On Delay Time	@Full Load Condition			2	S
Overshoot	@Full Load Condition			10	%
<b>PROTECTION</b>					
Short Circuit Protection	Protection will trigger when short circuit and will automatically recover after the fault mode is removed.	Hiccup Mode			
Over Current Protection	Protection will trigger when load current exceeds specified output current and will automatically recover after the fault mode is removed.	Hiccup Mode			
Over Voltage Protection	Protection will trigger when load voltage exceed specified output voltage and will automatically recover after the fault mode is removed.	Hiccup Mode			
Over Temperature Protection	Protection will trigger when driver overheats and automatically recover when cooled down.				
<b>ENVIRONMENTAL SPECIFICATIONS</b>					
Operating Temperature		-40		60	°C
Storage Temperature		-40		85	°C
Maximum Case Temperature				90	°C
Humidity		5		95	%
Life Rating	@120VAC Input, 100% Load, 60°C Case Temperature		80,000		Hours
MTBF	@40°C Ambient (~70°C Case Temp)		165,000		Hours

**SPECIFICATIONS**

All specifications are based on 25°C, Nominal Input Voltage, and Maximum Output Current unless otherwise noted.  
 We reserve the right to change specifications based on technological advances.

SPECIFICATION	TEST CONDITIONS	Min	Typ	Max	Unit
<b>GENERAL SPECIFICATIONS</b>					
Typ. Efficiency		See Table			
Withstand Voltage	Input to Output	2800VDC, 2mA			
Leakage Current	@277VAC, 60Hz Input			0.5	mA
<b>PHYSICAL SPECIFICATIONS</b>					
Weight		6.17lbs (2.8kg)			
Dimensions (L x W x H)		11.47in x 4.43in x 1.91in (291.3mm x 112.4mm x 48.4mm)			
Mounting		10.80in (274.3mm)			
Packing	Details	2.8kg/unit, 6pcs/carton, 216pcs/pallet			
	Carton Size	410 x 360 x 115mm			
	Carton Weight	18kg			
Case Material		Aluminum			
Wire Specifications	Input	12", UL Rated SJTW #18AWG x 3C			
	Output	12", UL rated SJTW #14AWG x 2C			
<b>SAFETY CHARACTERISTICS</b>					
Safety and EMC Compliance <sup>(1)</sup>		UL/cUL	UL 8750, Class P, Type HL		
		CE	EN61347-1 EN61347-2-13		
		FCC, 47CFR Part 15	ANSI C63.4:2009 Class B (Consumer Limit)		
		EN61000-3-2	Harmonic Current Emissions Class C		

**NOTES**

- This product is Listed to applicable standards and requirements by UL.  
*\*Due to advances in technology, specifications subject to change without notice.*

CHARACTERISTIC CURVES

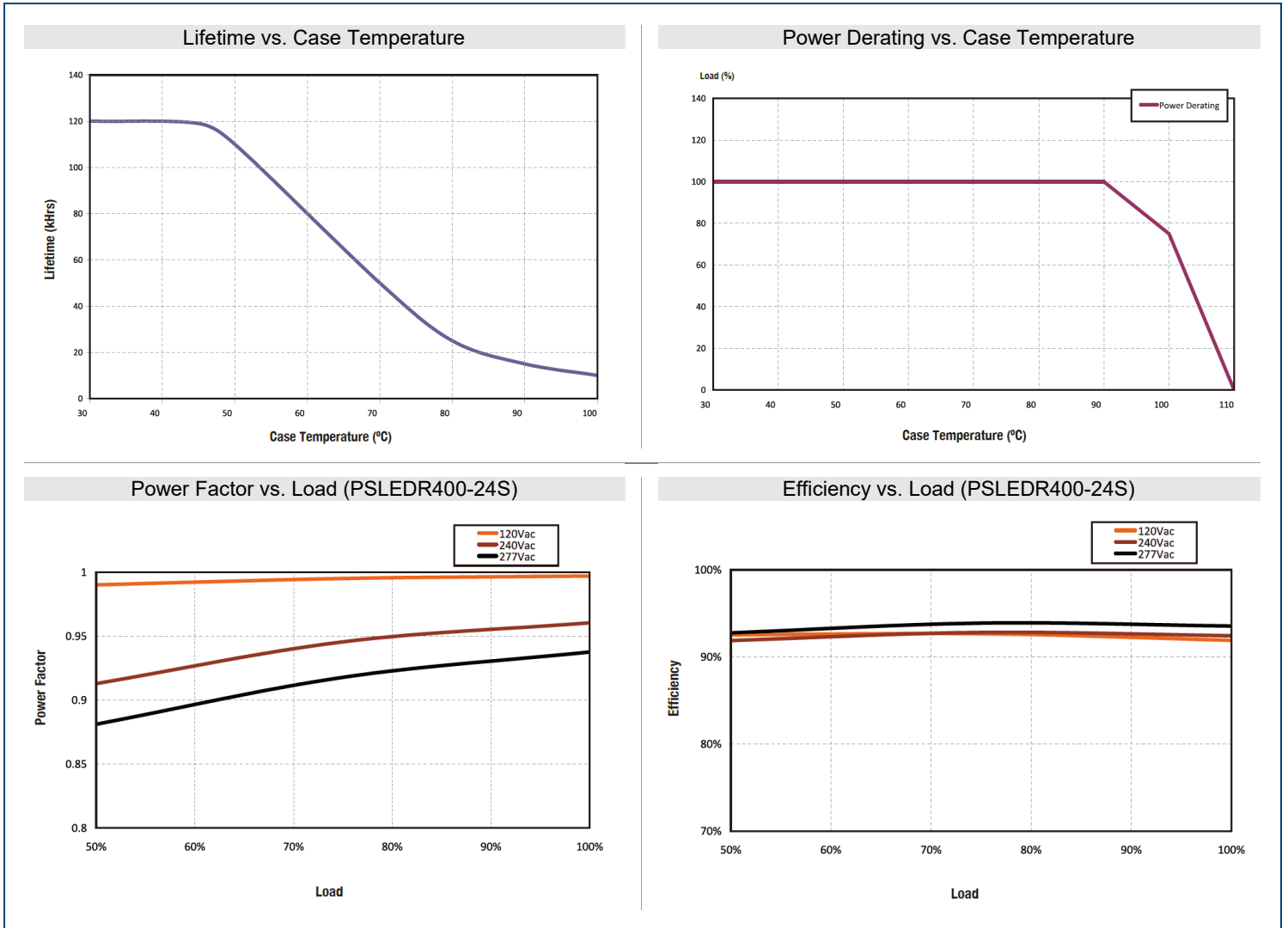

WIRING DIAGRAM

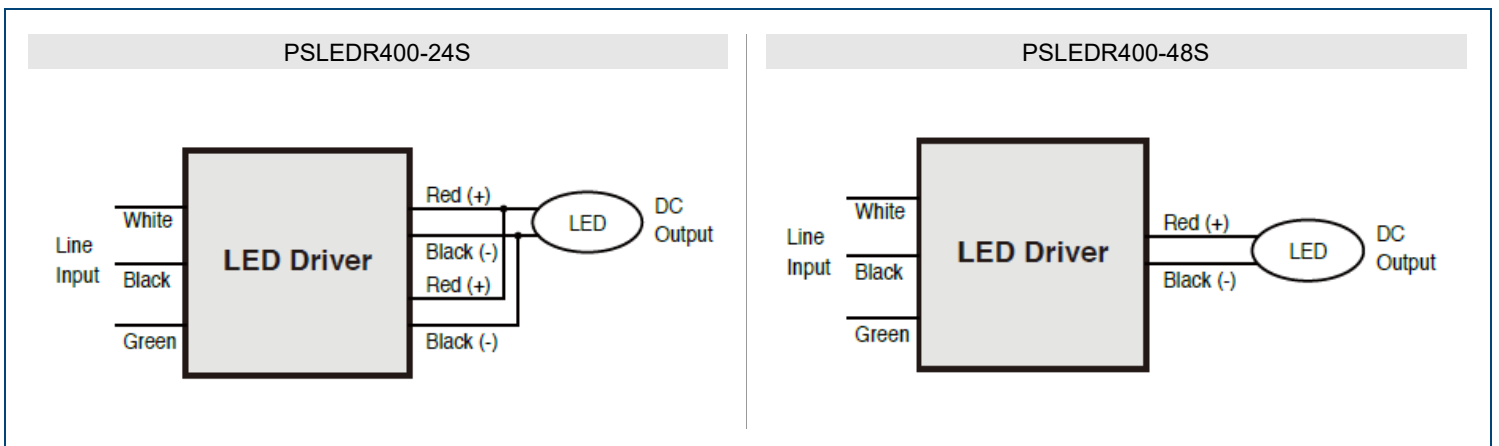

MECHANICAL DRAWINGS

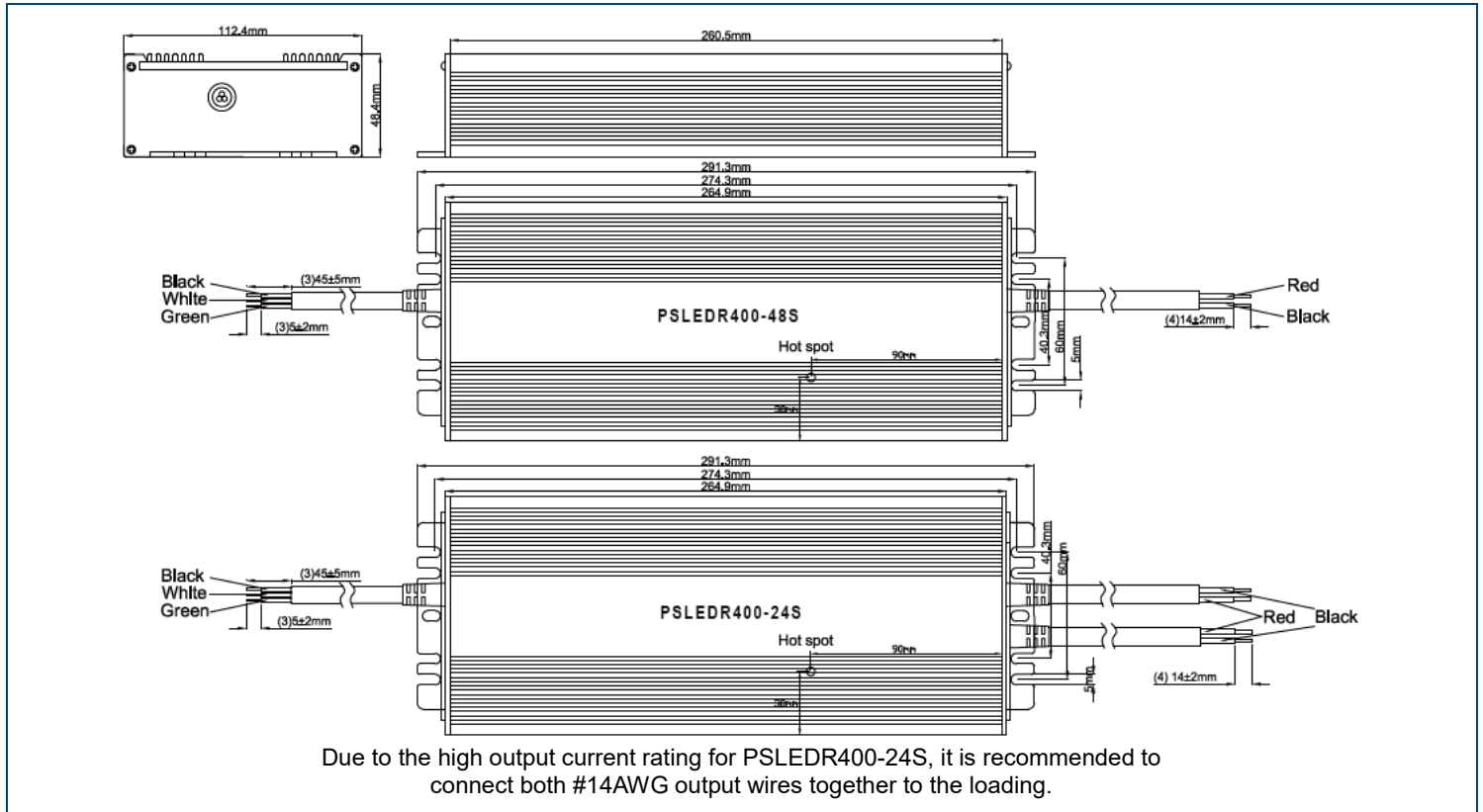

COMPANY INFORMATION

Wall Industries, Inc. has created custom and modified units for over 50 years. Our in-house research and development engineers will provide a solution that exceeds your performance requirements on-time and on budget. Our ISO9001: 2015 certification is just one example of our commitment to producing a high quality, well-documented product for our customers.

Our past projects demonstrate our commitment to you, our customer. Wall Industries, Inc. has a reputation for working closely with its customers to ensure each solution meets or exceeds form, fit and function requirements. We will continue to provide ongoing support for your project above and beyond the design and production phases. Give us a call today to discuss your future projects.

Contact **Wall Industries** for further information:

Phone: ☎ (603)778-2300  
 Toll Free: ☎ (888)597-9255  
 Fax: ☎ (603)778-9797  
 E-mail: [sales@wallindustries.com](mailto:sales@wallindustries.com)  
 Web: [www.wallindustries.com](http://www.wallindustries.com)  
 Address: 37 Industrial Drive  
 Exeter, NH 03833

©2019 Wall Industries, Inc. Specifications subject to change without notice. Wall Industries is not responsible for typographical errors. The information contained herein is for informational purposes only. This information is provided by Wall Industries and we make no representations or warranties of any kind, express or implied, about the completeness, accuracy, reliability, suitability or availability with respect to the information contained in this document for any purpose. All product and manufacturer names are trademarks or registered trademarks of their respective companies.