



Wall Industries, Inc.



Industrial Robotics

Since 1960, Wall Industries has been a leading provider of high-performance power solutions across a variety of industries and applications, now including industrial robotics. Industrial robotic systems are rapidly gaining growth and popularity in industrial processes as they help manufacturers improve efficiency, ease of use, and precision across various complicated operations.

Wall now offers a wide variety of highly specialized industrial robotic components. This includes several series of DC/DC converters and AC/DC supplies that come in wide power ranges and a variety of cases along with corresponding transceiver modules that help systems convert TTL/CMOS levels to CAN bus differential levels.

Integrating industrial robotics into manufacturing systems introduces many benefits to industrial processes like improving safety, speeding up labor-intensive tasks, and lowering long term costs. They also assist in several types of manufacturing processes including material handling, automated guided vehicles, sorting systems, palletizing robots, among other developing manufacturing technologies.

If you are beginning to integrate robotics into your manufacturing systems, Wall has the components you need. If you are looking for a modified or custom solution for your new system, or need development assistance, give us a call at (888) 597-9255.

We can't wait to power your success.

POWER COMPONENTS AND CORRESPONDING MODULES

- Compact Units
- Highly Specialized
- 1-600 Watts
- Single & Dual Outputs
- CAN Isolation Transceivers
- Industrial Busses

APPLICATIONS

- Sorting Systems
- Warehouse Automation
- Manufacturing Automation
- Car Manufacturing
- Palletizing Robotics
- Industrial Painting Robotics
- Material Handling Robotics
- Automated Guided Vehicles
- Next-generation technologies

THE WALL DIFFERENCE

- Speed
- Accessibility
- Expertise
- Flexibility

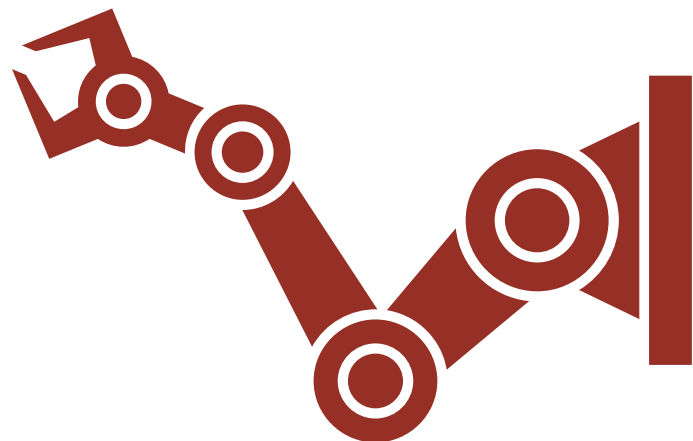

Industrial Robotic Components

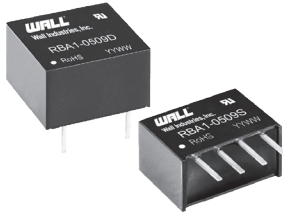

RBA1 SERIES

- 1 Watt of output power
- DIP or SIP Package
- High Efficiency
- EN60950 and UL60950 Safety Approvals



RBA30 SERIES

- 30 watts of output power
- Through Hole, Chassis Mount, or DIN Rail Package with Optional Heatsink
- 4:1 Input Range
- Six-Sided Shielding



DCBB10A SERIES

- Non Isolated
- Buck-Boost Converter
- Rated to 60VDC at 10A
- Adjustable Current and Voltage
- 1/8 Brick Package



RBCAN01 CAN ISOLATION TRANSCEIVER MODULE

- Industrial Bus
- Two-Port Isolation
- Can Support at Least 110 Nodes
- High Baud Rate
- Compact Size

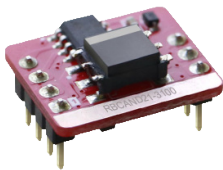

RBCAND21 CAN ISOLATION TRANSCEIVER MODULE

- Industrial Bus
- Single Channel
- DIP8 Package
- High Baud Rate
- EN60950 Safety Approval

Visit wallindustries.com for more!

Power Solution Examples

SORTINGROBOTS

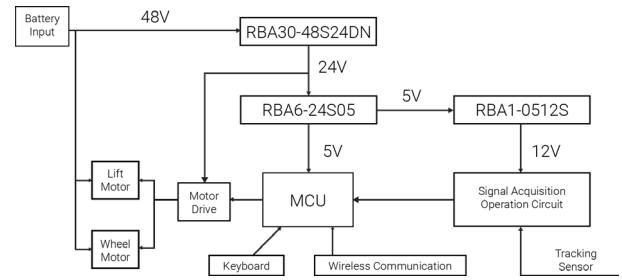

STORAGE ROBOTS

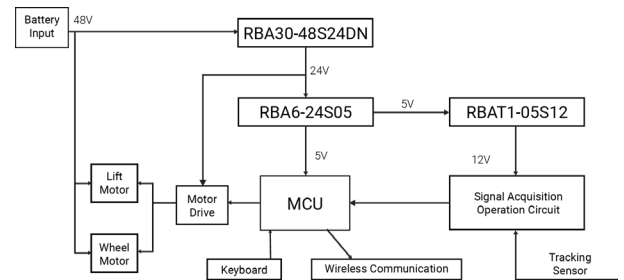

FORKLIFT AGVS

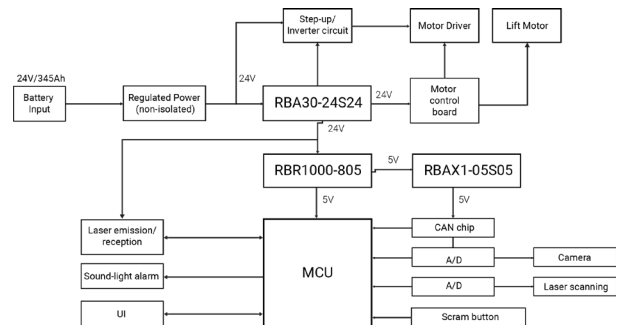

How can we help you?

To speak with our power supply and conversion specialists, contact us any time at 888-597-9255 or sales@wallindustries.com. We can't wait to power your success.

