



Size: 4.62in x 1.98in x 1.32in (117.3mm x 50.3mm x 33.5mm)

FEATURES

- 90~264VAC Input Voltage Range
- High Efficiency
- Level VI Compliant (besides 6A & 7A models)
- US, EU, UK, and Australian Plugs Available
- Over Current and Short Circuit Protection
- RoHS Compliant
- DC Cable=1m
- UL, FCC, CE, CB, PSE and RCM Approvals

DESCRIPTION

The WMICP65 series of AC/DC wall mount with interchangeable plug power supplies offers up to 65 watts of output power in a 4.62" x 1.98" x 1.32" package. This series consists of single output models with a wide input voltage range of 90~264VAC and either a US, EU, UK or Australian plug. Each model in this series has high efficiency, is RoHS compliant, and has over current and short circuit protection. This series has UL, CE, CB, and FCC safety approvals.

MODEL SELECTION TABLE

Model Number ⁽¹⁾	Input Voltage Range	Output Voltage ⁽²⁾	Max. Output Current	Ripple & Noise	Output Power	Efficiency Level
WMICP65-05X ~ WMICP65-239X	90~264VAC	5V~23.9V	7A ⁽³⁾	200mV Max.	60 Watts Max.	Level VI (Except for 6A & 7A)
WMICP65-24X ~ WMICP65-48X	90~264VAC	24V~48V	2700mA	200mV Max.	65 Watts Max	Level VI

SPECIFICATIONS

All specifications are based on 25°C, Nominal Input Voltage, and Maximum Output Current unless otherwise noted.
We reserve the right to change specifications based on technological advances.

SPECIFICATION	TEST CONDITIONS	Min	Typ	Max	Unit
INPUT SPECIFICATIONS					
Input Voltage Range		90	100~240	264	VAC
Input Frequency		47	60/50	63	Hz
Input AC Current	@100-240VAC Input & Full Load			1.5	A
Inrush Current	@264VAC Input, Cold Start			40	A
OUTPUT SPECIFICATIONS					
Output Voltage		See Table			
Line Regulation			±1		%
Load Regulation			±5		%
Energy Consumption	No Load, 100-240V		≤0.1		W
Output Power		See Table			
Output Current		See Table			
Ripple & Noise ⁽⁴⁾			200		mVp-p
Turn On Delay Time	@100VAC-240VAC Input & Full Load				
Hold Up Time	@Full Load & 115VAC/60Hz Input Turn Off at Worst Case	10			mS
	@Full Load & 230VAC/50Hz Input Turn Off at Worst Case	20			
Rise Time	@Rated Load			20	mS
Fall Time	@Full Load			20	mS
Output Overshoot/Undershoot	When the power is on or off			10	%
Transient Response	For load step from 25% to 50% to 25%, 50% to 75% to 50% R/S		0.25		A/uS
Transient Response Recovery Time			200		uS
Dynamic Response			5		%
PROTECTION					
Short Circuit Protection	The input power will decrease when the output rail shorts, the power supply should not damage and should self-recover when fault condition is removed.				
Over Current Protection	Output should hiccup when over currents are applied to the output rail and should self-recover when fault condition is removed				
Over Current Point Limited	@100-240VAC			10	A

SPECIFICATIONS

All specifications are based on 25°C, Nominal Input Voltage, and Maximum Output Current unless otherwise noted.
We reserve the right to change specifications based on technological advances.

SPECIFICATION	TEST CONDITIONS	Min	Typ	Max	Unit
ENVIRONMENTAL SPECIFICATIONS					
Operating Temperature		0		40	°C
Storage Temperature		-20		80	°C
Operating Relative Humidity		10		90	%RH
Storage Relative Humidity	Non-Condensing @Sea Level below 2,000 meters	5		95	%RH
Vibration	10 to 300Hz sweep at a constant acceleration of 1.0 G (Breadth:3.5mm) for 1 hour for each of the perpendicular axes X,Y,Z				
Drop In	Height: 1m; the product should be felled off on hardwood with the thickness of 20mm and hardwood should be put on a base of cement or on ground without flexibility. Apply two times on all surfaces & corners.				
Burn-In	Power supply should be burned-in for 4 hours under normal input and 80% rated load at 40°C±5°C				
GENERAL SPECIFICATIONS					
Efficiency	@Nominal Input	88			%
Leakage Current	@264VAC/50Hz			0.25	mA
Insulation Resistance	@Primary to Secondary, add 500VDC Test Voltage	50			mΩ
Dielectric Strength (Hi-Pot)	Primary to Secondary	3000VAC/10mA Max/60 Seconds			
	Primary to Secondary	3300VAC/5mA Max/3S			
PHYSICAL SPECIFICATIONS					
Dimensions (L x W x H)		4.62in x 1.98in x 1.32in (117.3mm x 50.3mm x 33.5mm)			
Weight	Main Unit	8.47oz (240g)			
	US/Australian Plug	0.35oz (10g)			
	EU	0.78oz (22g)			
	UK	0.99oz (28g)			
SAFETY CHARACTERISTICS					
Safety Approvals	UL ⁽⁶⁾ , FCC, CE, CB, PSE and RCM				
EMI	EN55022, EN61000-3-2, FCC Part 15 Class B, SAA111261EA Class				
Electrostatic Discharge	EN61000-4-2	Air Discharge ±8kV Contact Discharge ±4kV			Test Criteria B Test Criteria B
Radiated Electromagnetic Field Susceptibility	EN61000-4-3	Test Level: 3V/m (r.m.s) Test Level: 80-1000MHz, 80%AM (1KHz) sine-wave			Test Criteria A
Electric Fast Transient Immunity Req.	EN61000-4-4	Coupling: AC Input 0.5KV Coupling: AC Input 1KV			Test Criteria A Test Criteria B
Surge Capability Req.	EN61000	Surge Voltage: Common Mode N/A Surge Voltage: Differential Mode 1KV			Test Criteria A
Induced Radio Frequency Fields Conducted Disturbances Immunity Req.	EN61000-4-6	Test Level 3V			Test Criteria A

NOTES

- "X" in model number stands for plug type. "X" can either be "U" for US plug, "E" for EU plug, "K" for UK Plug, or "S" for Australian plug.
- Please specify output voltage within this range.
- 6A & 7A models **CANNOT** meet Level VI compliance.
- Ripple & Noise measurement is done by 20MHz bandwidth oscilloscope and the output paralleled a 0.1uF ceramic capacitor and a 47uF electrolysis capacitor (test under the condition of rated input and rated output)
- Assessment Criteria:

Acceptance Criteria	Performance
A	Agreed operation behavior within the specified limits
B	Time limited functional diminishment or malfunction during the tests is permitted. The function is self-reactivated by the unit following completion of the tests.
C	Malfunction is permitted. The function can be reactivated either by reconnection to the mains or by operator intervention.

- This product is Listed to applicable standards and requirements by UL.

**Due to advances in technology, specifications subject to change without notice.*

MECHANICAL DRAWINGS

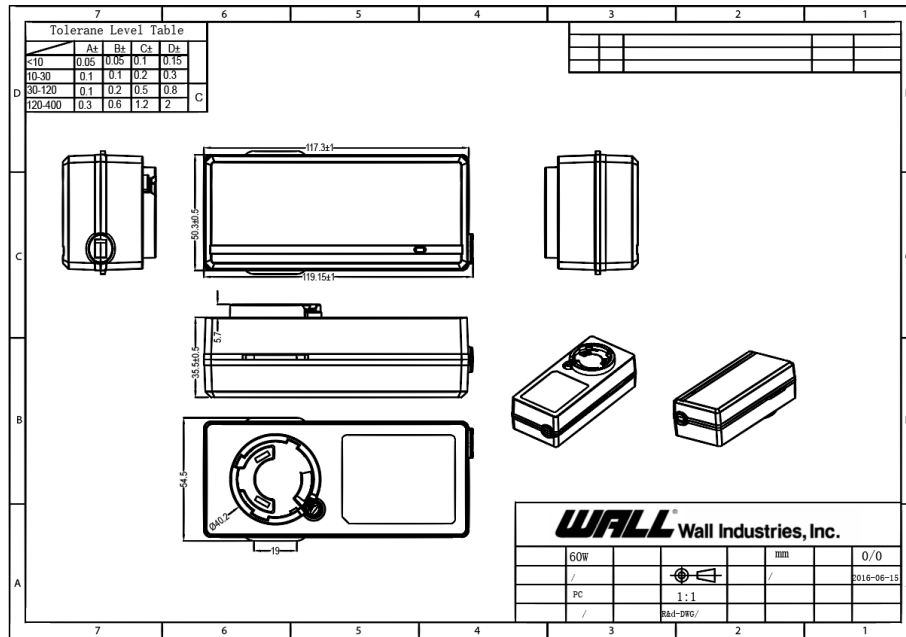

DC Cord Drawing

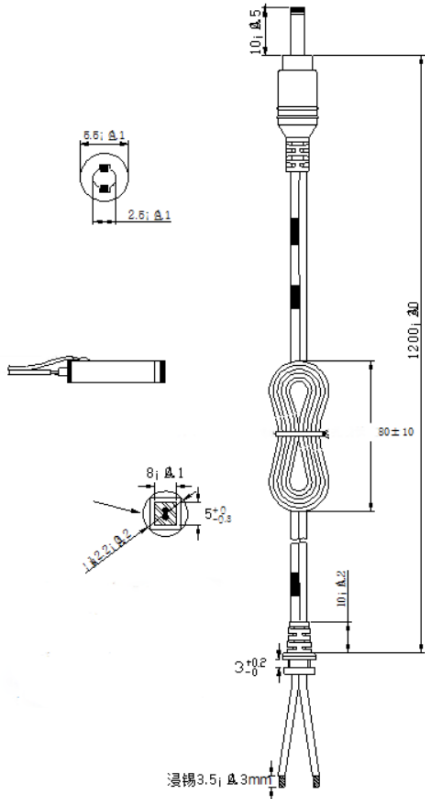

Label Drawing

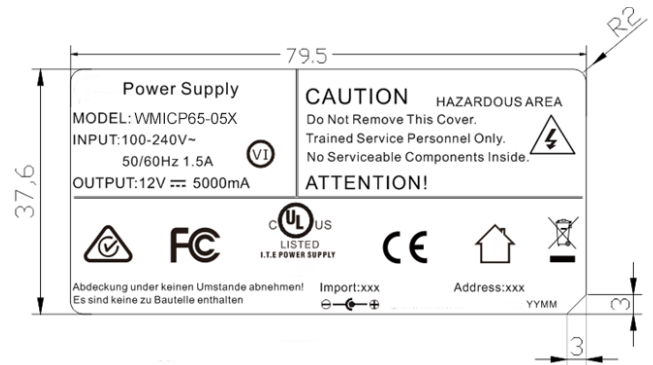

Packing

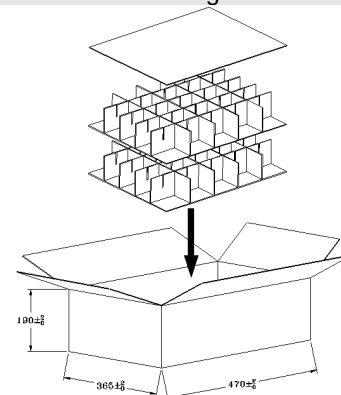

COMPANY INFORMATION

Wall Industries, Inc. has created custom and modified units for over 50 years. Our in-house research and development engineers will provide a solution that exceeds your performance requirements on-time and on budget. Our ISO9001: 2015 certification is just one example of our commitment to producing a high quality, well-documented product for our customers.

Our past projects demonstrate our commitment to you, our customer. Wall Industries, Inc. has a reputation for working closely with its customers to ensure each solution meets or exceeds form, fit and function requirements. We will continue to provide ongoing support for your project above and beyond the design and production phases. Give us a call today to discuss your future projects.

Contact **Wall Industries** for further information:

Phone: ☎ (603)778-2300
Toll Free: ☎ (888)597-9255
Fax: ☎ (603)778-9797
E-mail: sales@wallindustries.com
Web: www.wallindustries.com
Address: 37 Industrial Drive
Exeter, NH 03833

©2019 Wall Industries, Inc. Specifications subject to change without notice. Wall Industries is not responsible for typographical errors. The information contained herein is for informational purposes only. This information is provided by Wall Industries and we make no representations or warranties of any kind, express or implied, about the completeness, accuracy, reliability, suitability or availability with respect to the information contained in this document for any purpose. All product and manufacturer names are trademarks or registered trademarks of their respective companies.