



Size:
5.83 x 2.80 x 1.50 inches
148.0 x 71.0 x 38.0 mm

Weight:
1.5 lbs (680g)

FEATURES

- RoHS Compliant
- 3000VAC I/O Isolation
- 125 Watts Output Power
- High Efficiency up to 91.5%
- Free Air Convection
- Active PFC Function
- Meets EN55022 Class B (pending)
- UL/cUL 60950-1, CE, CB Safety Approvals (Pending)
- 12V, 15V, 24V, and 48V Single Outputs
- PCB Mountable Switching Power Supply
- Universal Input: 90-264VAC (120-370VDC)
- Short Circuit, Over Power, Over Voltage, and Over Temperature Protection
- Four M3 Mounting Holes on Bottom Side (Optional)

DESCRIPTION

The PSAQC125 series of AC/DC power supplies provides 125 Watts of output power in a 5.83" x 2.80" x 1.50" encapsulated PCB mountable package. This series consists of single output models with a universal input range of 90-264VAC (120-370VDC). Some features include active PFC function, 3000VAC I/O isolation, and high efficiency up to 91.5%. This series is also protected against short circuit, over power, over voltage, and over temperature conditions. All models are RoHS compliant and have UL/cUL 60950-1, CE, and CB safety approvals (pending) and meet EN55022 Class B (pending).

MODEL SELECTION TABLE

Model Number	Input Voltage Range	Output Voltage	Output Current	Ripple & Noise ⁽¹⁾	Output Power	Efficiency	Maximum Capacitive Load
PSAQC125-12S	90~264 VAC (120~370 VDC)	12 VDC	10.4A	130mVp-p	125W	90%	3,000µF
PSAQC125-15S		15 VDC	8.33A	150mVp-p	125W	90%	2,000µF
PSAQC125-24S		24 VDC	5.2A	240mVp-p	125W	90.5%	360µF
PSAQC125-48S		48 VDC	2.6A	480mVp-p	125W	91.5%	180µF

NOTES

1. Ripple & Noise is measured at 20MHz limited bandwidth and with 0.1µF and 47µF capacitors in parallel across the output.
2. Optional: four M3 mounting holes on the bottom side of the power supply. For ordering details please call factory.
3. This product is Listed to applicable standards and requirements by UL.

**Due to advances in technology, specifications subject to change without notice.*

DERATING CURVES

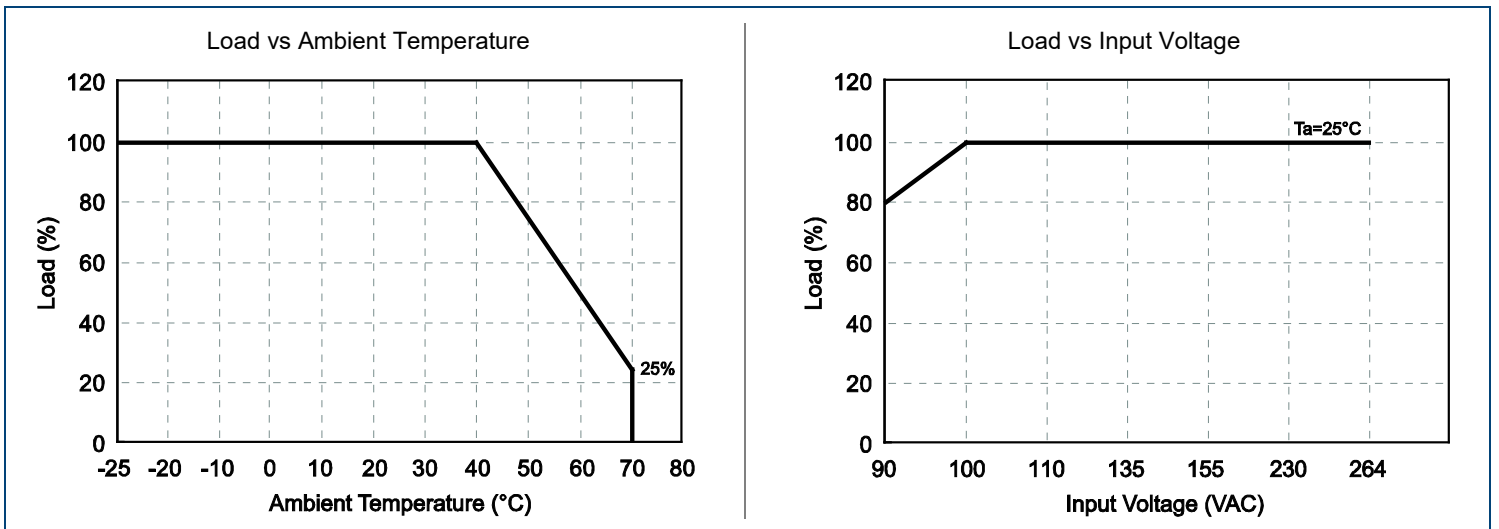

TECHNICAL SPECIFICATIONS: PSAQC125 SERIES

All specifications are based on 25°C, Nominal Input Voltage, and Maximum Output Current unless otherwise noted.
We reserve the right to change specifications based on technological advances.

SPECIFICATION		TEST CONDITIONS	Min	Typ	Max	Unit
INPUT SPECIFICATIONS						
Input Voltage	AC input voltage range		90		264	VAC
	DC input voltage range		120		370	VDC
Input Frequency			47		63	Hz
Input Current	At 115VAC and full load				2.0	A
	At 230VAC and full load				1.0	
Inrush Current (<2ms)	At 115VAC and cold start				35	A
	At 230VAC and cold start				70	
Power Factor	At 115VAC and full load		0.98			
	At 230VAC and full load		0.95			
OUTPUT SPECIFICATIONS						
Output Voltage			See Table			
Voltage Accuracy			-2		+2	%
Line Regulation	Low Line to High Line		-1		+1	%
Load Regulation	5% - 100% full load		-1		+1	%
Output Power			See Table			
Output Current			See Table			
Minimum Load			0			%
Ripple & Noise (20MHz BW)	Measured with 0.1µF and 47µF capacitors in parallel		See Table			
Max Capacitive Load	At 100~240VAC		See Table			
Hold-up Time	At 115VAC and 90% Vout		10			ms
Temperature Coefficient	0~50°C		-0.03		+0.03	%/°C
PROTECTION						
Short Circuit Protection			Hiccup mode, auto-recovery			
Over Voltage Protection			Zener diode clamp			
Over Power Protection			auto-recovery			
Over Temperature Protection			auto-recovery			
GENERAL SPECIFICATIONS						
Efficiency			See Table			
Isolation Voltage	Input to Output		3000			VAC
	Input to FG		1500			
	Output to FG		500			
Leakage Current					0.75	mA
ENVIRONMENTAL SPECIFICATIONS						
Operating Temperature	With derating (see derating curve)		-25		+70	°C
Storage Temperature			-25		+85	°C
Humidity					95	% RH
Cooling			Free air convection			
Vibration	10~500Hz, 10 min/1cycle for 60 min. each test along the X, Y, Z axis			2		G
MTBF	25°C (MIL-HDBK-217F, Notice 1)		250,000			hours
PHYSICAL SPECIFICATIONS						
Weight			1.5 lbs (680g)			
Dimensions (L x W x H)			5.83 x 2.80 x 1.50 in (148.0 x 71.0 x 38.0 mm)			
SAFETY & EMC						
Safety Approvals			UL60950-1 ⁽³⁾ , CE, and CB (pending)			
EMI (Conducted & Radiated Emissions)	Conductive plane to be connected to safety earth		EN 55022 class B (pending)			
EMS (Noise Immunity)			EN55024 (pending)			
Surge			1KV L-N, 2KV L N-FG (pending)			

EFFICIENCY VS LOAD CURVES

PSAQC125-12S

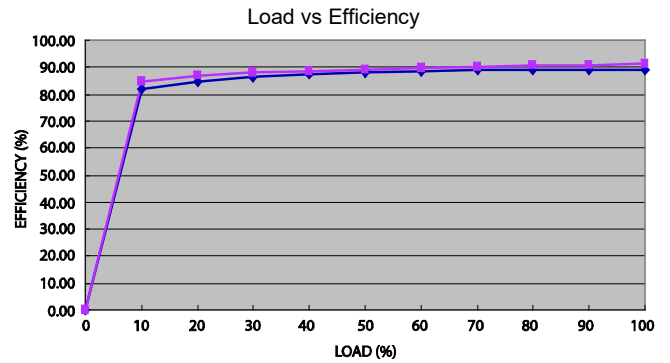
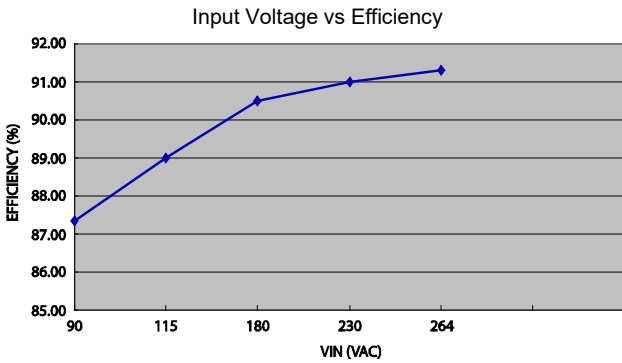

PSAQC125-15S

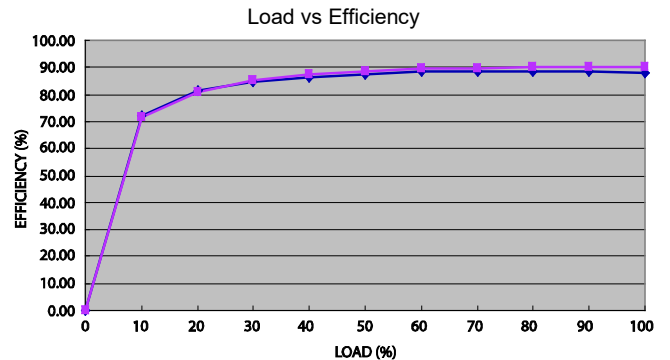
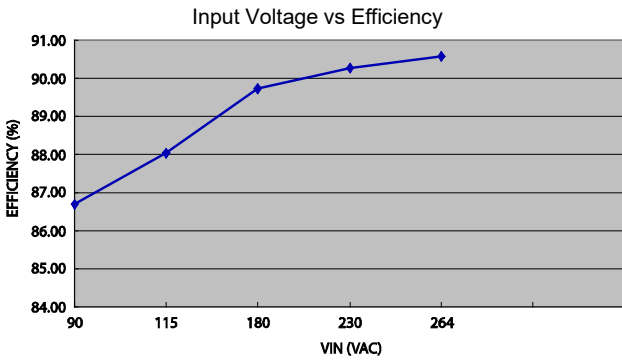

PSAQC125-24S

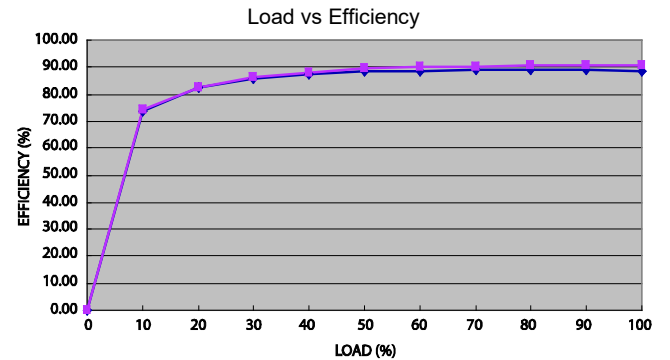
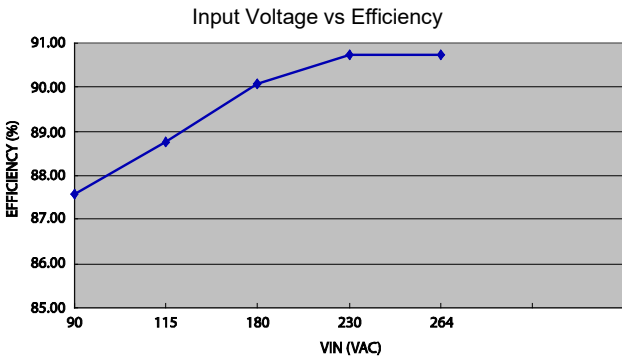

PSAQC125-48S

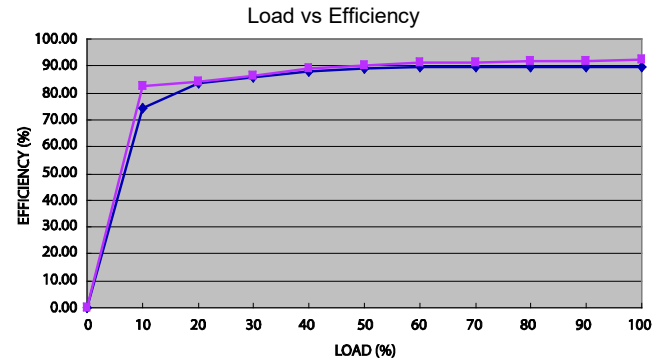
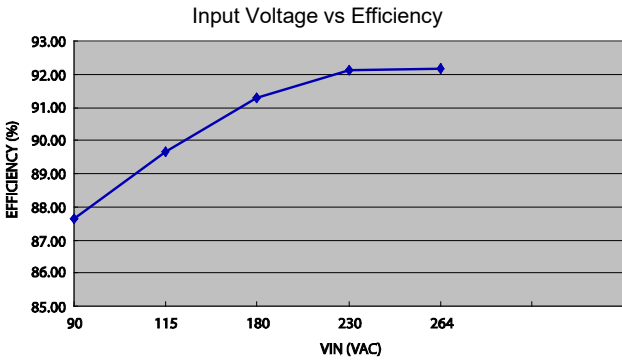

MECHANICAL DRAWING

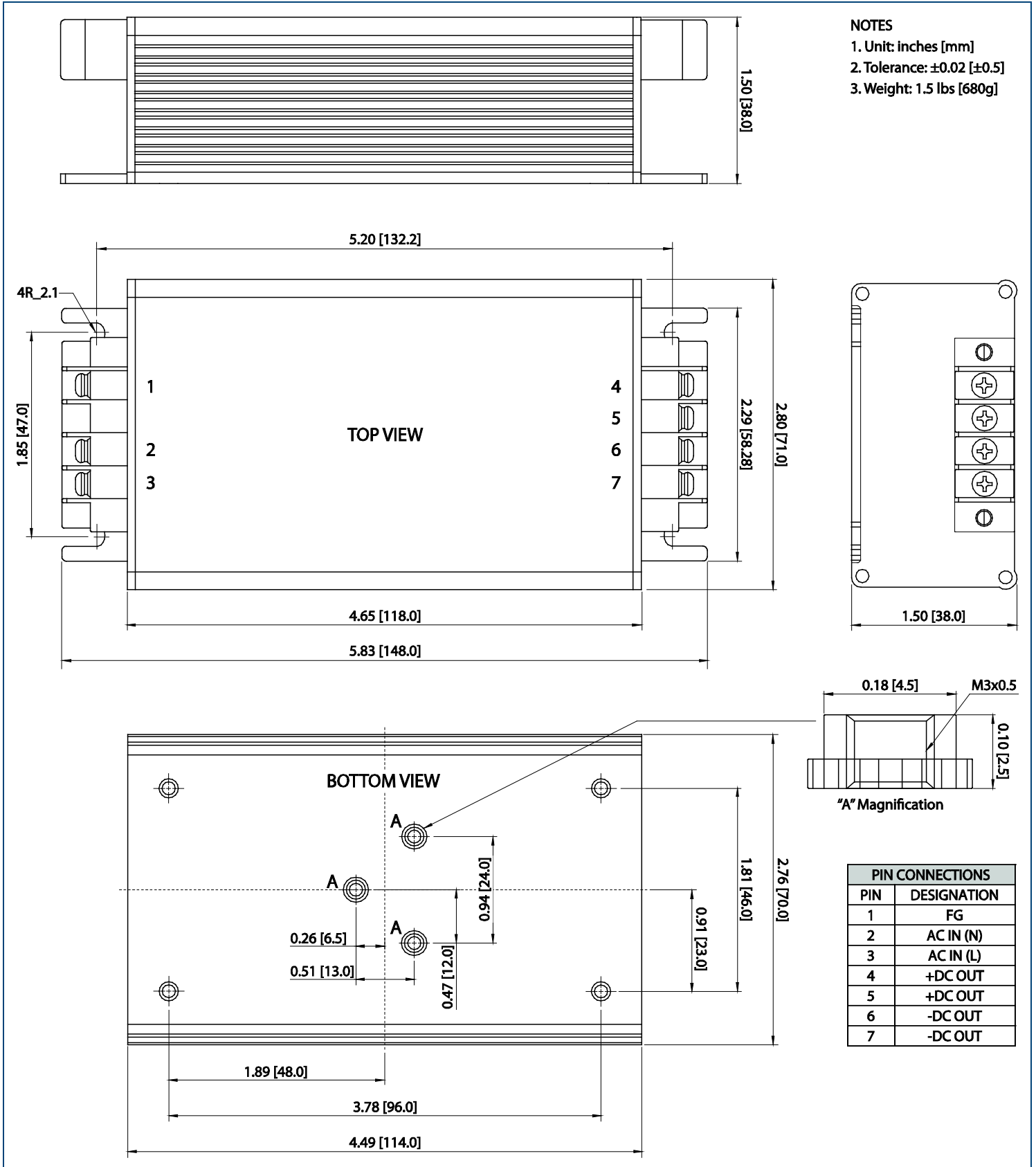

BLOCK DIAGRAM

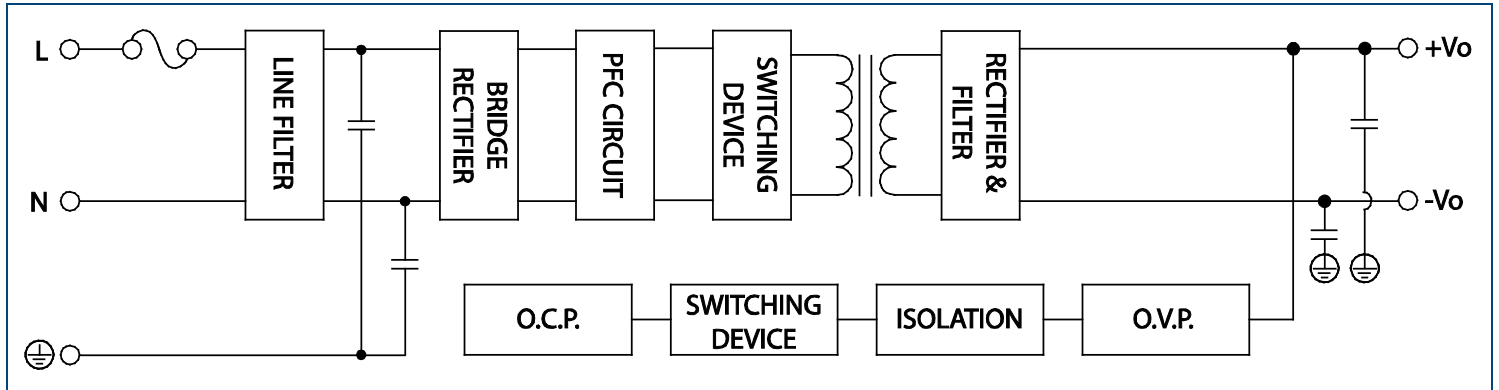

COMPANY INFORMATION

Wall Industries, Inc. has created custom and modified units for over 50 years. Our in-house research and development engineers will provide a solution that exceeds your performance requirements on-time and on budget. Our ISO9001: 2015 certification is just one example of our commitment to producing a high quality, well-documented product for our customers.

Our past projects demonstrate our commitment to you, our customer. Wall Industries, Inc. has a reputation for working closely with its customers to ensure each solution meets or exceeds form, fit and function requirements. We will continue to provide ongoing support for your project above and beyond the design and production phases. Give us a call today to discuss your future projects.

Contact **Wall Industries** for further information:

Phone: ☎(603)778-2300
Toll Free: ☎(888)597-9255
Fax: ☎(603)778-9797
E-mail: sales@wallindustries.com
Web: www.wallindustries.com
Address: 37 Industrial Drive
Exeter, NH 03833

©2019 Wall Industries, Inc. Specifications subject to change without notice. Wall Industries is not responsible for typographical errors. The information contained herein is for informational purposes only. This information is provided by Wall Industries and we make no representations or warranties of any kind, express or implied, about the completeness, accuracy, reliability, suitability or availability with respect to the information contained in this document for any purpose. All product and manufacturer names are trademarks or registered trademarks of their respective companies.