



FEATURES

- RoHS Compliant
- Efficiency up to 80%
- 1500VDC I/O Isolation
- Single and Dual Outputs
- MTBF > 2,000,000 Hours
- Internal SMT Construction
- UL94V-0 Packing Material
- Operating Temperature: -25°C to +75°C

DESCRIPTION

The MSLU series power modules are 1W DC/DC converters in a miniature “gull-wing” SMT package. These converters operate over input voltage ranges of 4.5~5.5VDC, 10.8~13.2VDC, and 21.6~26.4VDC. This series also has single and dual output voltages of 3.3, 5, 9, 12, 15, ±5, ±12, and ±15VDC. These converters’ impressive efficiencies enable them to deliver their fully rated output power from -25°C to +75°C without a heatsink or forced-air cooling. These converters are useful for a variety of applications including distributed power systems, data communication equipment, telecommunication equipment, and industrial robot systems.

SPECIFICATIONS: MSLU Series					
All specifications are based on 25°C, Nominal Input Voltage, and Maximum Output Current unless otherwise noted. We reserve the right to change specifications based on technological advances.					
SPECIFICATION	TEST CONDITIONS	Min	Nom	Max	Unit
INPUT (V_{in})					
Input Voltage Range	5V nominal input models	4.5	5	5.5	VDC
	12V nominal input models	10.8	12	13.2	
	24V nominal input models	21.6	24	26.4	
Reverse Polarity Input Current	All models			0.3	A
Input Surge Voltage (1000ms)	5V nominal input models	-0.7		9	VDC
	12V nominal input models	-0.7		18	
	24V nominal input models	-0.7		30	
Input Filter	All models	Internal Capacitor			
OUTPUT (V_o)					
Output Voltage		See Model Selection Table			
Output Voltage Balance	Dual Output, Balanced Loads		±0.1	±1.0	%
Load Regulation	I _o = 20% to 100%	See Model Selection Table			
Line Regulation	For V _{in} Change of 10%		±1.2	±1.5	%
Output Power				1	W
Output Current		See Model Selection Table			
Ripple & Noise (20MHz)			60	120	mV _{pk-pk}
Ripple & Noise (20MHz)	Over Line, Over Load, and Over Temperature			150	mV _{pk-pk}
Ripple & Noise (20MHz)				15	mVrms
PROTECTION					
Short Circuit Protection		0.5 seconds max.			
Input Fuse Recommendation	5V nominal input models	500mA slow-blow type			
	12V nominal input models	200mA slow-blow type			
	24V nominal input models	100mA slow-blow type			
GENERAL					
Efficiency		See Model Selection Table			
Switching Frequency		50	100	140	KHz
Isolation Voltage Rated (See Note 6)	60 seconds	1500			VDC
Isolation Voltage Test	Flash Test for 1 second	1650			VDC
Isolation Resistance	500VDC	1			GΩ
Isolation Capacitance	100KHz, 1V		40	100	pF
Internal Power Dissipation				450	mW
Max. Capacitive Load		See Model Selection Table			
Moisture Sensitivity Level (MSL) Temperature	IPC/JEDEC J-STD-20	Level 2			
ENVIRONMENTAL					
Operating Temperature (Ambient)	Ambient	-25		+75	°C
Operating Temperature (Case)	Case	-25		+90	°C
Storage Temperature		-25		+125	°C
Lead Temperature	1.5mm from case for 10 seconds			260	°C
Humidity				95	%
Cooling		Free air convection			
Temperature Coefficient			±0.01	±0.02	%/°C
MTBF	MIL-HDBK-217F @ 25°C, Ground Benign	2,000,000 hours			
PHYSICAL					
Weight	Single Output Models	0.06oz (1.7g)			
	Dual Output Models	0.07oz (2.0g)			
Dimensions (L x W x H)	Single Output Models	0.54 x 0.31 x 0.26 inches (13.7 x 8.0 x 6.7 mm)			
	Dual Output Models	0.64 x 0.31 x 0.26 inches (16.24 x 8.0 x 6.7 mm)			
Case Material		Non-conductive black plastic			
Flammability		UL94V-0			

MODEL SELECTION TABLES

SINGLE OUTPUT MODELS									
Model Number	Input Voltage	Output Voltage	Output Current ⁽¹⁾		Input Current		Max. Load Regulation	Efficiency ⁽²⁾	Maximum Capacitive Load
			Min	Max	No Load	Max Load			
MSLU5S33-300	5 VDC (4.5 ~ 5.5 VDC)	3.3 VDC	6mA	300mA	30mA	271mA	10%	73%	33µF
MSLU5S05-200		5 VDC	4mA	200mA		256mA	10%	78%	33µF
MSLU5S09-110		9 VDC	2mA	110mA		254mA	10%	78%	33µF
MSLU5S12-84		12 VDC	1.5mA	84mA		259mA	8%	78%	33µF
MSLU5S15-67		15 VDC	1mA	67mA		254mA	7%	79%	33µF
MSLU12S33-300	12 VDC (10.8 ~ 13.2 VDC)	3.3 VDC	6mA	300mA	15mA	112mA	8%	74%	33µF
MSLU12S05-200		5 VDC	4mA	200mA		109mA	8%	76%	33µF
MSLU12S09-110		9 VDC	2mA	110mA		106mA	8%	78%	33µF
MSLU12S12-84		12 VDC	1.5mA	84mA		106mA	5%	79%	33µF
MSLU12S15-67		15 VDC	1mA	67mA		105mA	5%	80%	33µF
MSLU24S33-300	24 VDC (21.6 ~ 26.4 VDC)	3.3 VDC	6mA	300mA	8mA	58mA	8%	72%	33µF
MSLU24S05-200		5 VDC	4mA	200mA		54mA	8%	78%	33µF
MSLU24S09-110		9 VDC	2mA	110mA		54mA	8%	77%	33µF
MSLU24S12-84		12 VDC	1.5mA	84mA		55mA	5%	77%	33µF
MSLU24S15-67		15 VDC	1mA	67mA		53mA	5%	79%	33µF

DUAL OUTPUT MODELS									
Model Number	Input Voltage	Output Voltage	Output Current ⁽¹⁾		Input Current		Max. Load Regulation	Efficiency ⁽²⁾	Maximum Capacitive Load
			Min	Max	No Load	Max Load			
MSLU5D05-100	5 VDC (4.5 ~ 5.5 VDC)	±5 VDC	±2mA	±100mA	30mA	270mA	10%	74%	33µF
MSLU5D12-42		±12 VDC	±0.8mA	±42mA		259mA	8%	78%	33µF
MSLU5D15-33		±15 VDC	±0.7mA	±33mA		254mA	7%	78%	33µF
MSLU12D05-100	12 VDC (10.8 ~ 13.2 VDC)	±5 VDC	±2mA	±100mA	15mA	113mA	8%	74%	33µF
MSLU12D12-42		±12 VDC	±0.8mA	±42mA		108mA	5%	78%	33µF
MSLU12D15-33		±15 VDC	±0.7mA	±33mA		104mA	5%	79%	33µF
MSLU24D05-100	24 VDC (21.6 ~ 26.4 VDC)	±5 VDC	±2mA	±100mA	9mA	57mA	8%	73%	33µF
MSLU24D12-42		±12 VDC	±0.8mA	±42mA		54mA	5%	78%	33µF
MSLU24D15-33		±15 VDC	±0.7mA	±33mA		53mA	5%	78%	33µF

**Due to advances in technology, specifications subject to change without notice.*

NOTES

1. The MSLU series requires a minimum output loading to maintain specified regulations. Operation under no-load conditions will not damage these devices; however they may not meet all listed specifications.
2. Efficiency: typical value measured at max load.
3. All DC/DC converters should be externally fused at the front end for protection.
4. Other input and output voltages may be available, please contact factory.
5. It is not recommended to use water-washing processes on surface mount units.
6. For 3000VDC I/O isolation voltage see the MSLUH series.

BLOCK DIAGRAMS

Single Output

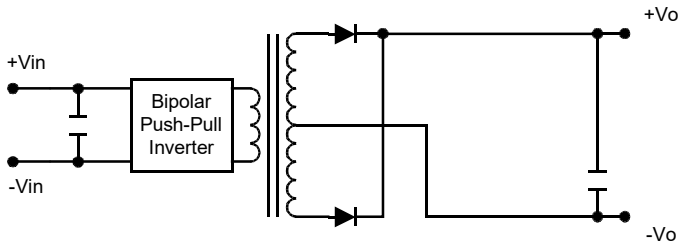

Dual Output

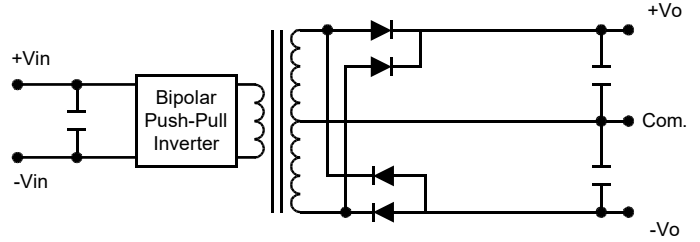

GRAPHS AND CURVES

Efficiency vs Input Voltage (Single Output)

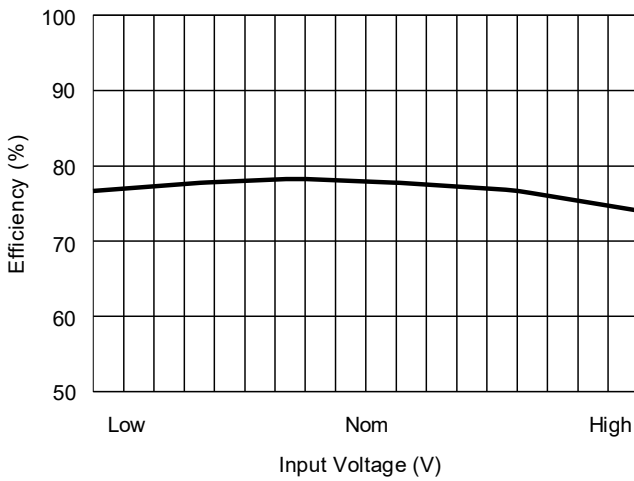

Efficiency vs Input Voltage (Dual Output)

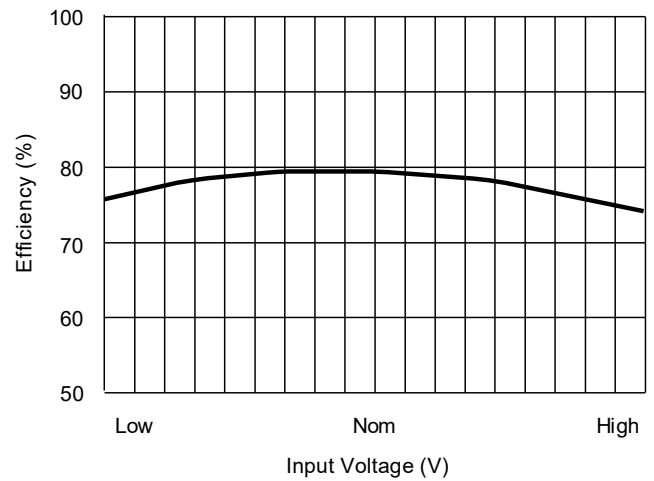

Efficiency vs Output Load (Single Output)

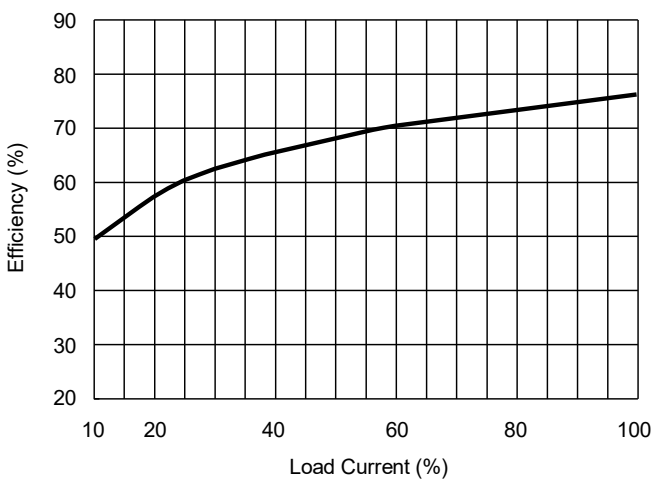

Efficiency vs Output Load (Dual Output)

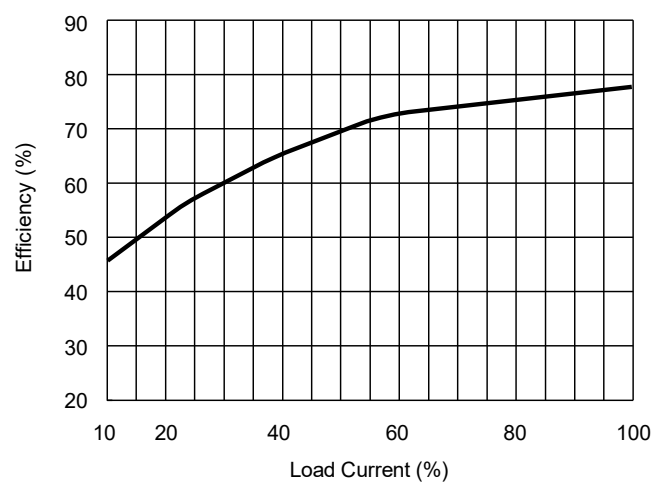

Tolerance Envelope Graph (3.3V & 5V Outputs)

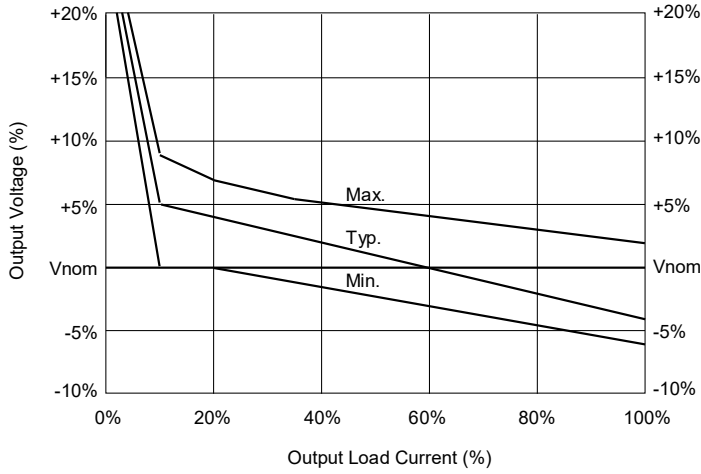

Tolerance Envelope Graph (All Other Outputs)

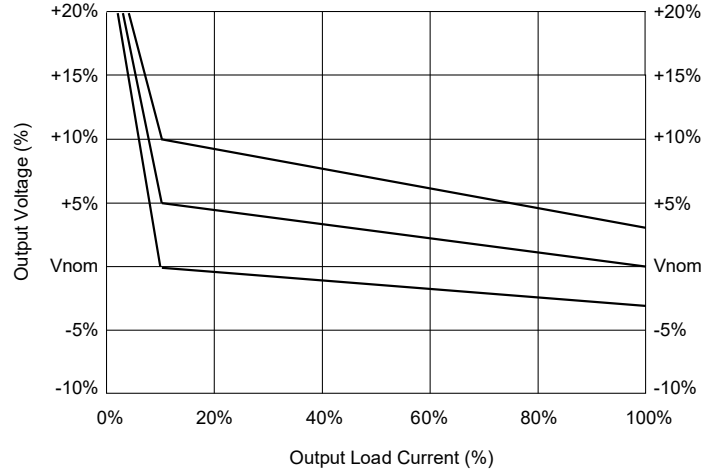

DERATING CURVE

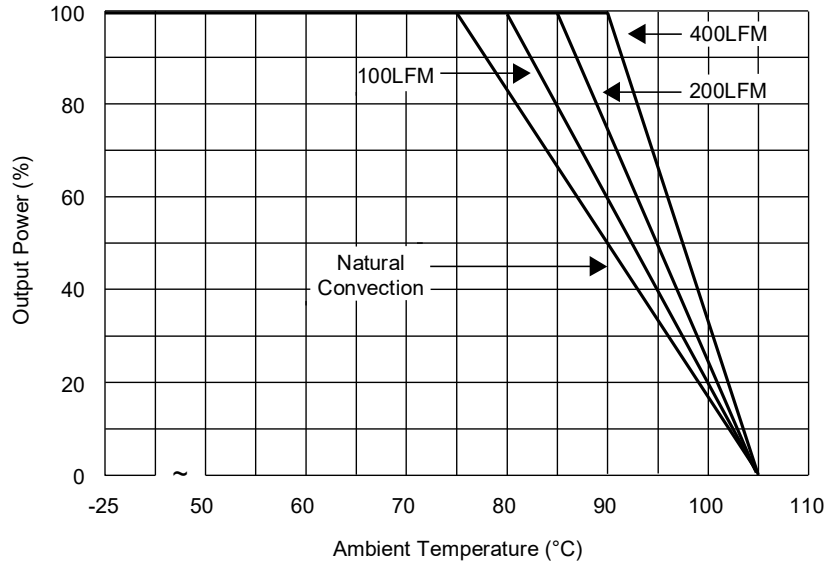

MECHANICAL DRAWING

CONNECTING PIN PATTERNS

Unit: inches [mm]

Single Output

Top View (2.54mm / 0.1 inch grids)

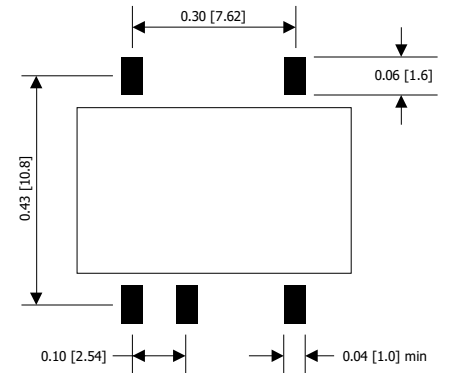
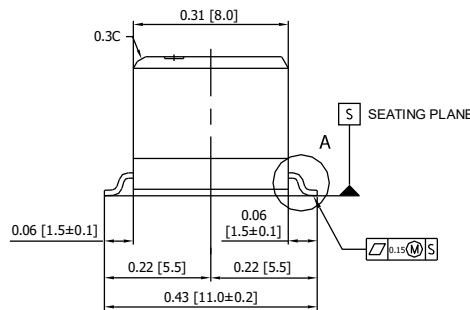
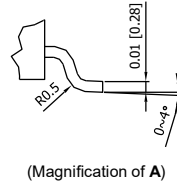
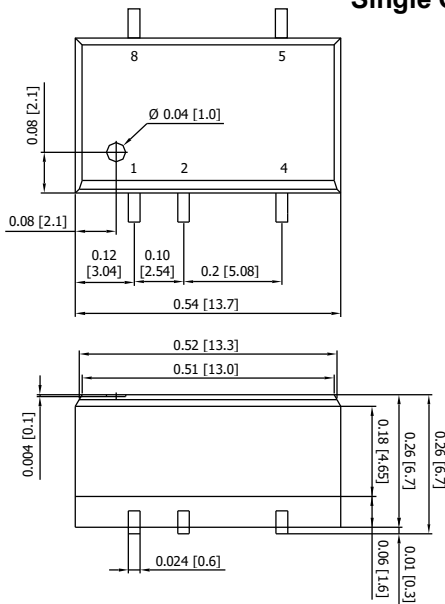

PIN CONNECTIONS		
Pin	Single Output	Dual Output
1	-Vin	-Vin
2	+Vin	+Vin
3	No Pin	No Pin
4	-Vout	Common
5	+Vout	-Vout
6	No Pin	No Pin
7	No Pin	+Vout
8	NA	No Pin
9		No Pin
10		NA

NA: Not available for electrical connection

Dual Output

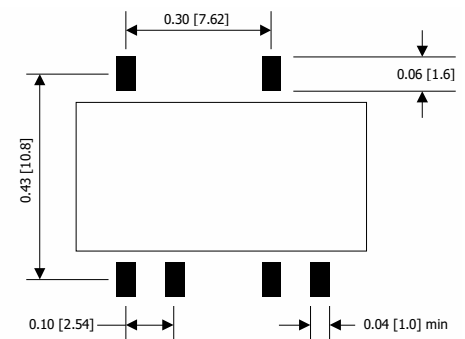
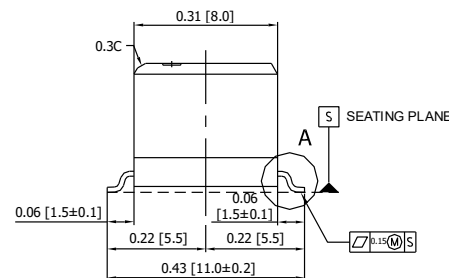
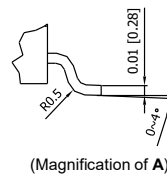
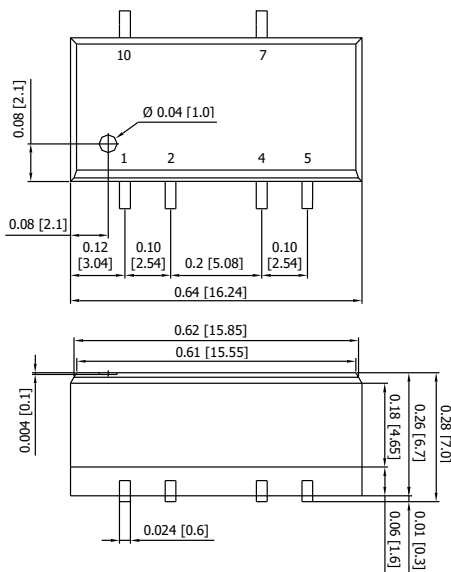

1. Tolerance: X.XX±0.01 [X.X±0.25]
 X.XXX±0.004 [X.XX±0.10]
2. Pin: ±0.002 [±0.05]

DESIGN & FEATURE CONSIDERATIONS

Input Source Impedance

The power module should be connected to a low ac-impedance input source. Highly inductive source impedances can affect the stability of the power module. In applications where power is supplied over long lines and output loading is high, it may be necessary to use a capacitor at the input to ensure startup. A capacitor mounted close to the power module helps ensure stability of the unit. It is recommended to use a good quality low Equivalent Series Resistance (ESR < 1.0Ω at 100KHz) capacitor of 2.2μF for the 5V input models, a 1.0μF for the 12V input models, and a 0.47μF for the 24V input models.

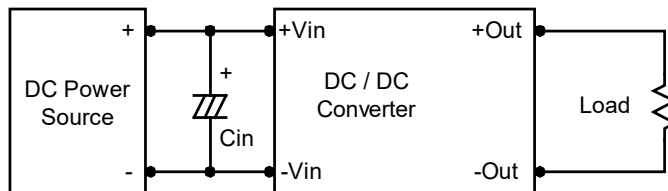

Maximum Capacitive Load

The MSLU series has a limit of maximum connected capacitance at the output. The power module may be operated in current limiting mode during start-up, affecting the ramp-up and the startup time. For optimal performance we recommend a maximum load of 33μF.

TEST CONFIGURATIONS

Input Reflected-Ripple Current Test Setup

Input reflected-ripple current is measured with an inductor L_{in} (4.7μH) and C_{in} (220μF, ESR < 1.0Ω at 100KHz) to simulate source impedance.

Capacitor C_{in} offsets possible battery impedance.

Current ripple is measured at the input terminals of the module. Measurement bandwidth is 0-500 KHz.

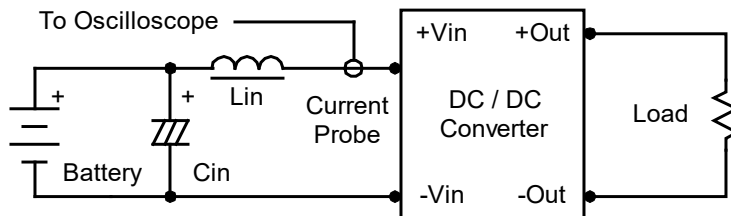

Peak-to-Peak Output Noise Measurement Test

Use a C_{out} 0.33μF ceramic capacitor.

Scope measurement should be made by using a BNC socket; measurement bandwidth is 0 ~ 20MHz. Position the load between 50mm and 75mm from the DC/DC Converter.

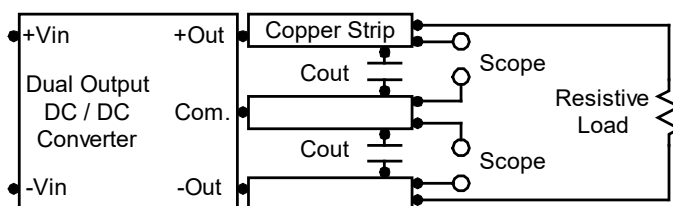
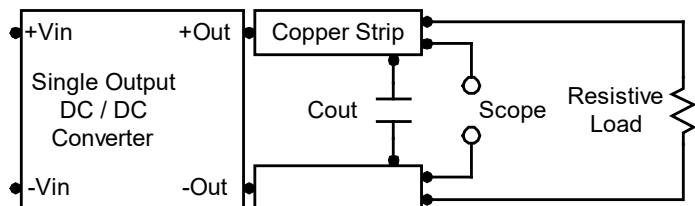

Output Ripple Reduction

A good quality low ESR capacitor placed as close as possible across the load will give the best ripple and noise performance. To reduce output ripple, it is recommended to use 3.3 μ F capacitors at the output.

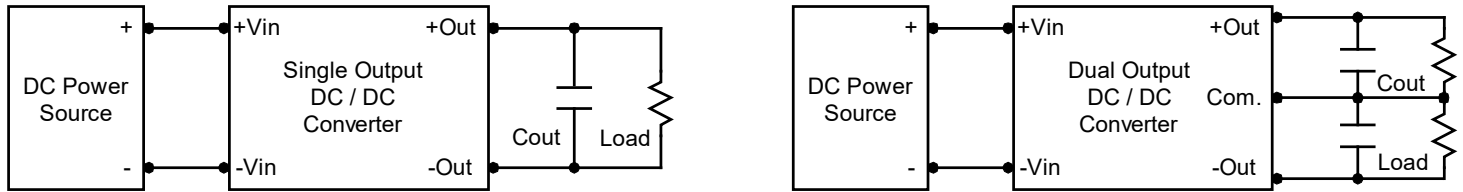

Thermal Considerations

Many conditions affect the thermal performance of the power module, such as orientation, airflow over the module, and board spacing. To avoid exceeding the maximum temperature rating of the components inside the power module, the case temperature must be kept below 90°C. The derating curves are determined from measurements obtained in an experimental apparatus.

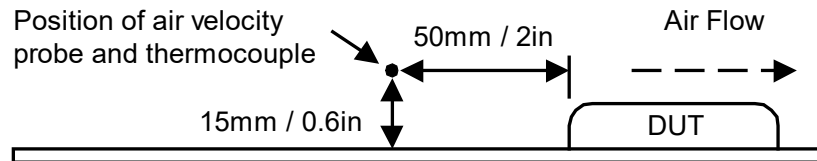

COMPANY INFORMATION

Wall Industries, Inc. has created custom and modified units for over 50 years. Our in-house research and development engineers will provide a solution that exceeds your performance requirements on-time and on budget. Our ISO9001: 2015 certification is just one example of our commitment to producing a high quality, well-documented product for our customers.

Our past projects demonstrate our commitment to you, our customer. Wall Industries, Inc. has a reputation for working closely with its customers to ensure each solution meets or exceeds form, fit and function requirements. We will continue to provide ongoing support for your project above and beyond the design and production phases. Give us a call today to discuss your future projects.

Contact **Wall Industries** for further information:

Phone: ☎ (603)778-2300
Toll Free: ☎ (888)597-9255
Fax: ☎ (603)778-9797
E-mail: sales@wallindustries.com
Web: www.wallindustries.com
Address: 37 Industrial Drive
Exeter, NH 03833

©2019 Wall Industries, Inc. Specifications subject to change without notice. Wall Industries is not responsible for typographical errors. The information contained herein is for informational purposes only. This information is provided by Wall Industries and we make no representations or warranties of any kind, express or implied, about the completeness, accuracy, reliability, suitability or availability with respect to the information contained in this document for any purpose. All product and manufacturer names are trademarks or registered trademarks of their respective companies.