

FEATURES

- 8 Watts Output Power
- Output Current up to 2A
- High Efficiency up to 85%
- Five-Sided Continuous Shield
- 2:1 Wide Input Voltage Range
- Fixed Switching Frequency (300KHz)
- Standard 1.25 x 0.8 x 0.4 Inch Package
- ISO9001 Certified Manufacturing Facilities
- Compliant to RoHS EU Directive 2002/95/EC
- Standard 24 Pin DIP Package & SMT Type Package

APPLICATIONS

- Measurement
- Wireless Network
- Telecom/Datacom
- Industry Control System
- Semiconductor Equipment



SPECIFICATIONS: LANCW8 Series

All specifications apply @ 25°C ambient unless otherwise noted.

INPUT SPECIFICATIONS

Input Voltage Range.....	12V nominal input	9-18VDC
	24V nominal input	18-36VDC
	48V nominal input	36-75VDC
Input Filter	Pi Type	
Input Surge Voltage (100ms max)	12V input.....	36VDC
	24V input.....	50VDC
	48V input.....	100VDC
Input Reflected Ripple Current (nominal Vin and full load).....	20mA _{p-p}	
Start Up Time (nominal Vin and constant resistive load).....	700ms max.	
Remote ON/OFF (See Note 6)		
(Positive Logic).....	DC-DC ON	Open or 3.5V < Vr < 12V
	DC-DC OFF	Short or 0V < Vr < 1.2V
Input Current of Remote Control Pin (nominal Vin).....	-0.5mA ~ +0.5mA	
Remote Off State Input Current (nominal Vin)	2.5mA	

OUTPUT SPECIFICATIONS

Output Voltage	see table	
Voltage Accuracy (nominal Vin and full load).....	±1%	
Output Current	see table	
Output Power	8 watts max.	
Line Regulation (LL to HL at FL).....	±0.2%	
Load Regulation (no load to full load)	Single Output (DIP)	±0.5%
	Single Output (SMT).....	±1%
	Dual Output (SMT, DIP).....	±1%
Cross Regulation (Dual) (Asymmetrical load 25% / 100% FL)	±5%	
Minimum Load.....	0%	
Ripple/Noise (20 MHz BW).....	50mV _{p-p}	
Temperature Coefficient.....	±0.02% / °C max.	
Transient Response Recovery Time (25% load step).....	200us	

PROTECTION SPECIFICATIONS

Over Load Protection (% of full load at nominal input)	150% max.
Short Circuit Protection.	Continuous, automatic recovery

GENERAL SPECIFICATIONS

Efficiency.....	see table
Switching Frequency.....	300KHz typ.

GENERAL SPECIFICATIONS (Continued)

Isolation Voltage	
Input to Output	1600VDC min.
Input (Output) to Case (DIP).....	1600VDC min.
Input (Output) to Case (SMT)	1000VDC min.
Isolation Resistance	10 ⁹ ohms min.
Isolation Capacitance.....	300pF max.

ENVIRONMENTAL SPECIFICATIONS

Operating Temperature	-40°C ~ +85°C (with derating)
Storage Temperature	-55°C ~ +105°C
Maximum Case Temperature	100°C
Relative Humidity (non-condensing).....	5% to 95% RH
Thermal Impedance (Natural Convection).....	20°C / Watt
Thermal Shock.....	MIL-STD-810F
Vibration.....	10~55Hz, 10G, 30 minutes along X, Y, and Z
MTBF (See Note 1).....	3.053 x 10 ⁶ hours

PHYSICAL SPECIFICATIONS

Weight	DIP Type.....	16g (0.55 oz)
	SMT Type.....	18g (0.62 oz)
Dimensions	1.25 x 0.80 x 0.40 inches (31.8 x 20.3 x 10.2 mm)	
Case Material.....	Nickel-coated copper	
Base Material.....	Non-conductive black plastic	
Potting material	Epoxy (UL94-V0)	
Shielding.....	five - sided	

SAFETY & EMC

Approvals and Standards.....	IEC60950-1, UL60950-1 ⁽⁹⁾ , EN60950-1	
EMI (Note 7)	EN55022.....	Class A
ESD	EN61000-4-2.....	Air ±8KV Perf. Criteria B
		Contact ±6KV
Radiated Immunity	EN61000-4-3	10V/m Perf. Criteria A
Fast Transient.....	EN61000-4-4	±2KV Perf. Criteria B
Surge (See Note 8).....	EN61000-4-5	±1KV Perf. Criteria B
Conducted Immunity	EN61000-4-6	10 Vrms Perf. Criteria A

Due to advances in technology, specifications subject to change without notice

OUTPUT VOLTAGE / CURRENT RATING CHART

Model Number	Input Range	Output Voltage	Output Current		Output ⁽⁴⁾ Ripple & Noise	Input Current		Efficiency ⁽⁴⁾	Capacitor ⁽⁵⁾ Load Max
			Min. load	Full load		No load ⁽³⁾	Full load ⁽²⁾		
LANC123.3W8	12 VDC (9 – 18 VDC)	3.3 VDC	0mA	2000mA	50mVp-p	10mA	724mA	80%	3300uF
LANC1205W8		5 VDC	0mA	1500mA	50mVp-p	15mA	791mA	83%	1600uF
LANC1212W8		12 VDC	0mA	666mA	50mVp-p	13mA	792mA	88%	350uF
LANC1215W8		15 VDC	0mA	533mA	50mVp-p	20mA	802mA	87%	240uF
LANC1205DW8		±5 VDC	0mA	±800mA	50mVp-p	15mA	843mA	83%	±1000uF
LANC1212DW8		±12 VDC	0mA	±333mA	50mVp-p	20mA	802mA	87%	±160uF
LANC1215DW8	±15 VDC	0mA	±267mA	50mVp-p	20mA	824mA	85%	±100uF	
LANC243.3W8	24 VDC (18 – 36 VDC)	3.3 VDC	0mA	2000mA	50mVp-p	10mA	362mA	80%	3300uF
LANC2405W8		5 VDC	0mA	1500mA	50mVp-p	30mA	396mA	83%	1600uF
LANC2412W8		12 VDC	0mA	666mA	50mVp-p	13mA	406mA	86%	350uF
LANC2415W8		15 VDC	0mA	533mA	50mVp-p	15mA	411mA	85%	240uF
LANC2405DW8		±5 VDC	0mA	±800mA	50mVp-p	15mA	427mA	82%	±1000uF
LANC2412DW8		±12 VDC	0mA	±333mA	50mVp-p	15mA	406mA	86%	±160uF
LANC2415DW8	±15 VDC	0mA	±267mA	50mVp-p	13mA	411mA	85%	±100uF	
LANC483.3W8	48 VDC (36 – 75 VDC)	3.3 VDC	0mA	2000mA	50mVp-p	7mA	181mA	80%	3300uF
LANC4805W8		5 VDC	0mA	1500mA	50mVp-p	8mA	198mA	83%	1600uF
LANC4812W8		12 VDC	0mA	666mA	50mVp-p	10mA	203mA	86%	350uF
LANC4815W8		15 VDC	0mA	533mA	50mVp-p	10mA	203mA	86%	240uF
LANC4805DW8		±5 VDC	0mA	±800mA	50mVp-p	8mA	205mA	85%	±1000uF
LANC4812DW8		±12 VDC	0mA	±333mA	50mVp-p	8mA	200mA	87%	±160uF
LANC4815DW8	±15 VDC	0mA	±267mA	50mVp-p	7mA	201mA	87%	±100uF	

NOTES

- BELLCORE TR-NWT-000332. Case I: 50% Stress, Temperature at 40°C. (Ground fixed and controlled environment).
- Maximum value at nominal input voltage and full load of standard type.
- Typical value at nominal input voltage and no load.
- Typical value at nominal input voltage and full load.
- Test by minimum Vin and constant resistive load.
- The ON/OFF control pin voltage is referenced to -Vin.
- The LANCW8 Series can meet EN55022 Class A with an external capacitor in parallel with the input pins.
 Recommended: 12Vin: 4.7µF/25V
 24Vin: N/A.
 48Vin: N/A.
- An external filter capacitor is required if the module has to meet EN61000-4-5. The filter capacitor Wall Industries suggests: Nippon chemi-con KY Series, 220µF/100V, ESR 48mΩ.

**Due to advances in technology, specifications subject to change without notice*

DERATING CURVE & EFFICIENCY GRAPHS

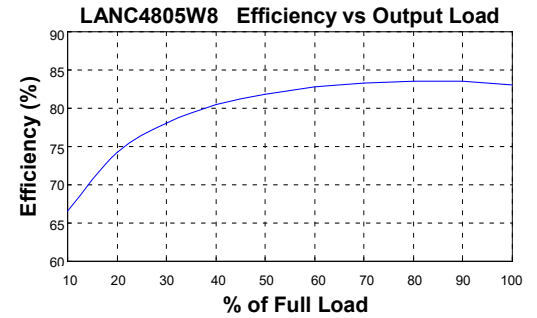
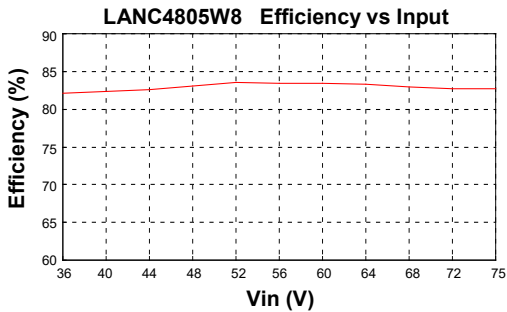
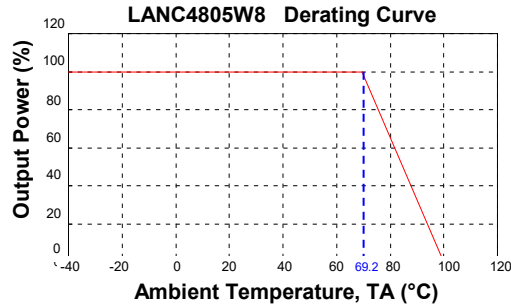

MECHANICAL DRAWING

- All dimensions are in inches (mm)
Tolerance: X.XX±0.02 (X.X±0.5)
X.XXX±0.01 (X.XX±0.25)
- Pin pitch tolerance ±0.01 (0.25)

DIP TYPE

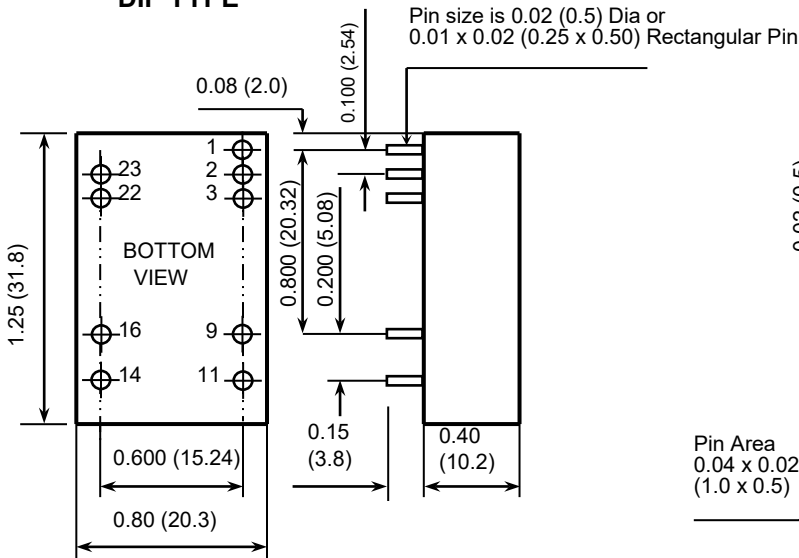

SMT TYPE

(add suffix "S")

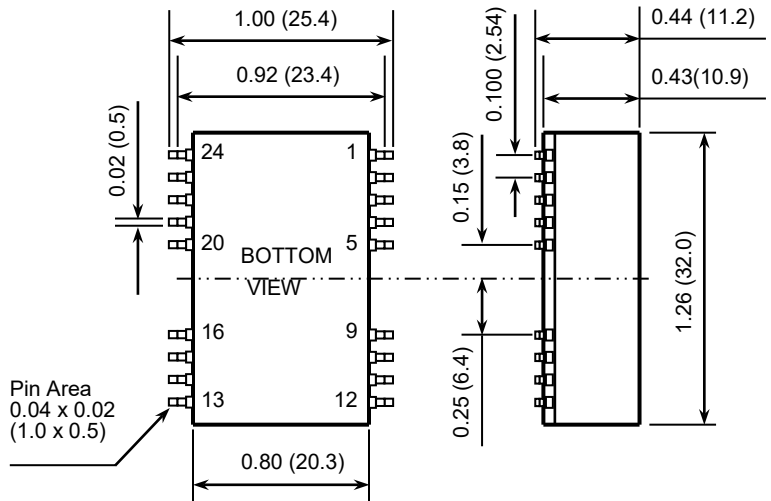

(DIP) PIN CONNECTION

PIN	SINGLE	DUAL	PIN	SINGLE	DUAL
1	CTRL	CTRL			
2	-INPUT	-INPUT	23	+INPUT	+INPUT
3	-INPUT	-INPUT	22	+INPUT	+INPUT
9	NC	COMMON	16	-OUTPUT	COMMON
11	NC	-OUTPUT	14	+OUTPUT	+OUTPUT

(SMT) PIN CONNECTION

PIN	SINGLE	DUAL	PIN	SINGLE	DUAL
1	CTRL	CTRL			
2	-INPUT	-INPUT	23	+INPUT	+INPUT
3	-INPUT	-INPUT	22	+INPUT	+INPUT
9	NC	COMMON	16	-OUTPUT	COMMON
11	NC	-OUTPUT	14	+OUTPUT	+OUTPUT
Others	NC	NC	Others	NC	NC

FIGURE 1

Recommended Filter for EN55022 Class B Compliance

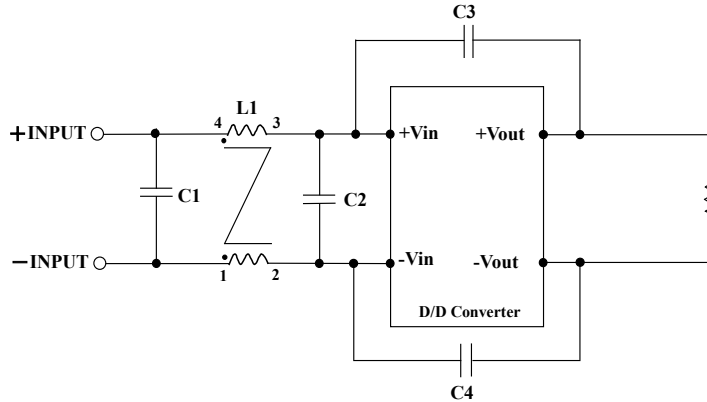
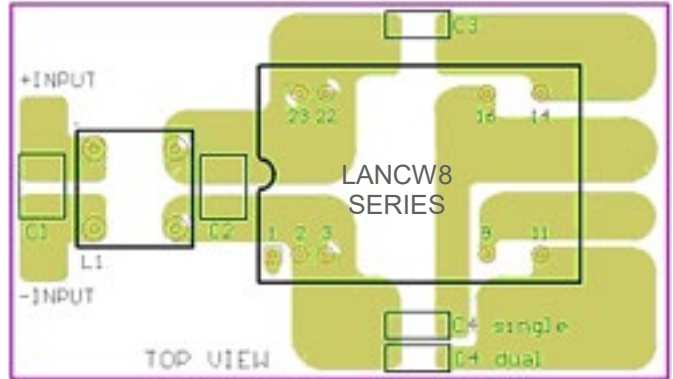

FIGURE 2

Recommended EN55022 Class B Filter Circuit Layout



The components used in the Figure 1, together with the manufacturers' part numbers for these components, are as follows:

	C1	C2	C3	C4	L1
LANC12xxW8	4.7uF/50V	N/A	1000pF/2KV	1000pF/2KV	325uH Common Choke
LANC24xxW8	6.8uF/50V	N/A	1000pF/2KV	1000pF/2KV	325uH Common Choke
LANC48xxW8	2.2uF/100V	2.2uF/100V	1000pF/2KV	1000pF/2KV	325uH Common Choke

COMPANY INFORMATION

Wall Industries, Inc. has created custom and modified units for over 50 years. Our in-house research and development engineers will provide a solution that exceeds your performance requirements on-time and on budget. Our ISO9001: 2015 certification is just one example of our commitment to producing a high quality, well-documented product for our customers.

Our past projects demonstrate our commitment to you, our customer. Wall Industries, Inc. has a reputation for working closely with its customers to ensure each solution meets or exceeds form, fit and function requirements. We will continue to provide ongoing support for your project above and beyond the design and production phases. Give us a call today to discuss your future projects.

Contact **Wall Industries** for further information:

Phone: ☎(603)778-2300
 Toll Free: ☎(888)597-9255
 Fax: ☎(603)778-9797
 E-mail: sales@wallindustries.com
 Web: www.wallindustries.com
 Address: 37 Industrial Drive
 Exeter, NH 03833

©2019 Wall Industries, Inc. Specifications subject to change without notice. Wall Industries is not responsible for typographical errors. The information contained herein is for informational purposes only. This information is provided by Wall Industries and we make no representations or warranties of any kind, express or implied, about the completeness, accuracy, reliability, suitability or availability with respect to the information contained in this document for any purpose. All product and manufacturer names are trademarks or registered trademarks of their respective companies.