

Wall Industries, Inc.

DCQEB100 SERIES

2:1 Input Voltage Ranges
Industry Standard Quarter-Brick Package
Up to 100 Watts, Single Outputs
DC/DC Power Converters



APPLICATIONS

- Telecom/Datacom
- Wireless Networks
- Industry Control Systems
- Semiconductor Equipment
- Distributed Power Architectures

OPTIONS

- Heatsinks
- Pin Lengths
- Thru-Hole Inserts
- Negative Logic Remote ON/OFF

FEATURES

- Up to 100 Watts Output Power
- Single Outputs
- Output Current up to 30A
- Industry Standard Quarter-Brick Package: 2.28" x 1.45" x 0.50"
- Under Voltage Lockout
- Fixed Switching Frequency
- Input to Output Isolation: 1600VDC
- 2:1 Wide Input Voltage Range
- High Efficiency up to 90%
- No Minimum Load Required
- Adjustable Output Voltage
- Threaded Inserts and Thru-Hole Inserts Available
- Short Circuit, Over Voltage, Over Current, and Over Temp. Protection
- Compliant to RoHS EU Directive 2002/95/EC
- CE Mark Meets 2006/95/CE, 93/68/EEC, and 2004/108/EC
- UL60950-1, EN60950-1, and IEC60950-1 Safety Approvals (See Note 12)

DESCRIPTION

The DCQEB100 series of DC/DC power converters provides up to 100 Watts of output power in an industry standard 2.28" x 1.45" x 0.50" quarter-brick package and footprint. This series consists of single output models with 2:1 input voltage ranges of 18-36VDC or 36-75VDC. Some features include high efficiency up to 90%, adjustable output voltage, remote sense, and positive or negative remote ON/OFF control. This series is RoHS compliant and has UL60950-1, EN60950-1, and IEC60950-1 safety approvals (see note 12). Several different options are available for this series including negative remote ON/OFF control, heatsinks, pin lengths, and thru-hole inserts. Please call factory for more details.

SPECIFICATIONS: DCQE100 SERIES						
All specifications are based on 25°C, Nominal Input Voltage, and Maximum Output Current unless otherwise noted. We reserve the right to change specifications based on technological advances.						
SPECIFICATION	TEST CONDITIONS		Min	Nom	Max	Unit
INPUT SPECIFICATIONS						
Input Voltage Range	24VDC nominal input models		18	24	36	VDC
	48VDC nominal input models		36	48	75	
Start-up Voltage	24VDC nominal input models				18	VDC
	48VDC nominal input models				36	
Shutdown Voltage	24VDC nominal input models		15			VDC
	48VDC nominal input models		32			
Input Surge Voltage	24VDC nominal input models				50	VDC
	48VDC nominal input models			100ms	100	
Input Current			See Table			
Input Filter			L-C Type			
OUTPUT SPECIFICATIONS						
Output Voltage			See Table			
Line Regulation	Low line to high line at full load		-0.2		+0.2	%
Load Regulation	No load to full load		-0.3		+0.3	%
Voltage Accuracy			-1.5		+1.5	%
Voltage Adjustability (See Note 5)			-20		+10	%
Output Power			See Table			
Output Current			See Table			
Minimum Load			0			%
Ripple & Noise	Measured at nominal input and full load with 20MHz BW and 1µF M/C and 10µF T/C capacitors in parallel.			100		mVp-p
Transient Response Recovery Time	25% load step change			250		µs
Start-Up Time	Power Up	Nominal input and constant resistive load			25	ms
	Remote ON/OFF				25	ms
Remote Sense (See Note 5)				10		% Vo
Temperature Coefficient			-0.02		+0.02	%/°C
PROTECTION						
Over Voltage Protection Threshold	Non-latching Hiccup				120	% Vo
Over Current Protection Threshold			110		140	% Io
Short Circuit Protection			Hiccup, automatic recovery			
Over Temperature Protection					+110	°C
GENERAL SPECIFICATIONS						
Efficiency	Nominal input and full load		See Table			
Switching Frequency			243	270	297	KHz
Isolation Voltage	Input to Output	For 1 minute	1600			VDC
	Input to Base-plate	For 1 minute	1000			VDC
	Output to Base-plate	For 1 minute	1000			VDC
Isolation Resistance			10			MΩ
Isolation Capacitance					2500	pF
REMOTE ON/OFF (See Note 6)						
Positive Logic (standard)	DC/DC ON		Open or 3V < Vr < 15V			
	DC/DC OFF		Short or 0V < Vr < 1.2V			
Negative Logic (optional)	DC/DC ON		Short or 0V < Vr < 1.2V			
	DC/DC OFF		Open or 3V < Vr < 15V			
Input Current of Remote Control Pin	Nominal input		-0.5		1	mA
Remote Off Input Current	Nominal input			2.5		mA
ENVIRONMENTAL SPECIFICATIONS						
Operating Base-Plate Temperature (See Note 7)			-40		+100	°C
Storage Temperature			-55		+125	°C
Relative Humidity	Non-condensing		5		95	% RH
Thermal Shock			MIL-STD-810F			
Vibration			MIL-STD-810F			
MTBF (See Note 1)	BELLCORE TR-NWT-000332		2,500,000			Hours
	MIL-HDBK-217F		631,100			Hours
PHYSICAL SPECIFICATIONS						
Weight			1.46oz (42g)			
Dimensions (L x W x H)			2.28 x 1.45 x 0.50 inches (57.9 x 36.8 x 12.7 mm)			
Case Material			Aluminum base-plate			
SAFETY & EMC CHARACTERISTICS						
Safety Approvals			UL60950-1 ⁽¹⁴⁾ , IEC60950-1, EN60950-1 (DCQE100-48S1.8, 48S2.5, 48S3.3, and 48S05 have approvals; approvals pending for all other models)			
EMI (See Note 8)	EN55022					Class A
Radiated Immunity	EN61000-4-3		10 V/m			Perf. Criteria A
Fast Transient (See Note 9)	EN61000-4-4		±2KV			Perf. Criteria B
Surge (See Note 9)	EN61000-4-5		±1KV			Perf. Criteria B
Conducted Immunity	EN61000-4-6		10 Vrms			Perf. Criteria A

MODEL SELECTION TABLE									
Model Number ⁽¹²⁾	Input Voltage Range	Output Voltage	Output Current		Ripple & Noise ⁽⁴⁾	Input Current		Output Power	Efficiency ⁽⁴⁾
			Min. load	Full load		No Load ⁽³⁾	Full Load ⁽²⁾		
DCQEB100-24S3.3	24VDC (18 - 36 VDC)	3.3 VDC	0mA	25A	100mVp-p	80mA	3997mA	82.5W	89%
DCQEB100-24S05		5 VDC	0mA	20A	100mVp-p	120mA	4845mA	100W	90%
DCQEB100-24S12		12 VDC	0mA	8.33A	100mVp-p	50mA	4843mA	100W	90%
DCQEB100-24S15		15 VDC	0mA	6.67A	100mVp-p	60mA	4847mA	100W	90%
DCQEB100-48S1.8	48 VDC (36 - 75 VDC)	1.8 VDC	0mA	30A	100mVp-p	55mA	1389mA	54W	85%
DCQEB100-48S2.5		2.5 VDC	0mA	30A	100mVp-p	50mA	1883mA	75W	87%
DCQEB100-48S3.3		3.3 VDC	0mA	25A	100mVp-p	75mA	2022mA	82.5W	89%
DCQEB100-48S05		5 VDC	0mA	20A	100mVp-p	80mA	2422mA	100W	90%
DCQEB100-48S12		12 VDC	0mA	8.33A	100mVp-p	65mA	2422mA	100W	90%
DCQEB100-48S15		15 VDC	0mA	6.67A	100mVp-p	65mA	2424mA	100W	90%

NOTES

- BELLCORE TR-NWT-000332. Case 1: 80% Stress, Temperature at 40°C. MIL-HDBK-217F Notice2 @Ta=25°C, Full load (Ground, Benign, controlled environment).
- Maximum value at nominal input voltage and full load.
- Typical value at nominal input voltage and no load.
- Typical value at nominal input voltage and full load.
- Maximum output deviation is +10% inclusive of trim. If remote sense is not being used the +SENSE should be connected to its corresponding +OUTPUT and likewise the -SENSE should be connected to its corresponding -OUTPUT.
- The remote ON/OFF control pin voltage is referenced to -INPUT. To order negative logic Remote ON/OFF control add the suffix "R" to the model number (Ex: DCQEB100-48S05R).
- Heatsink is optional and P/N: 7G-0029A-F, 7G-0030A-F, 7G-0031A-F, and 7G-0032A-F.
- The DCQEB100 series meets EN55022 Class A and Class B only with external components added before the input pins to the converter.
- An external input filter capacitor is required if the module has to meet EN61000-4-4 and EN61000-4-5. We recommend Nippon chemi-con KY series, 220µF/100V, ESR 48mΩ.
- BASE-PLATE GROUNDING: EMI can be reduced when you connect the four screw bolts to the shield plane.
- The converter is provided with basic insulation.
- Safety Approvals: DCQEB100-48S1.8, 48S2.5, 48S3.3, and 48S05 have safety approvals; approvals pending for all other models.
- This series comes with several different options: Negative remote ON/OFF control, pin lengths, thru-hole inserts, and heatsinks.
- This product is Listed to applicable standards and requirements by UL.

CAUTION: The power module is not internally fused. An input line fuse must always be used.

Due to advances in technology, specifications subject to change without notice.

DERATING

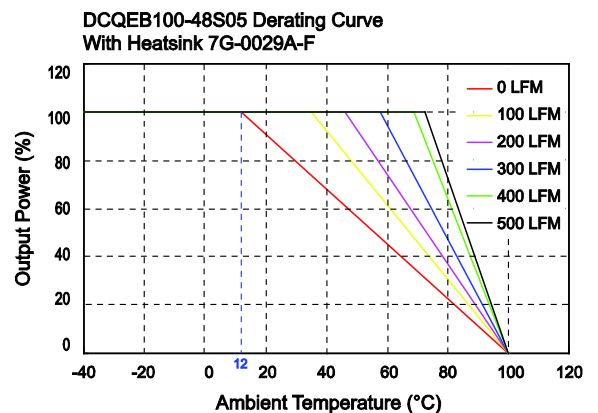
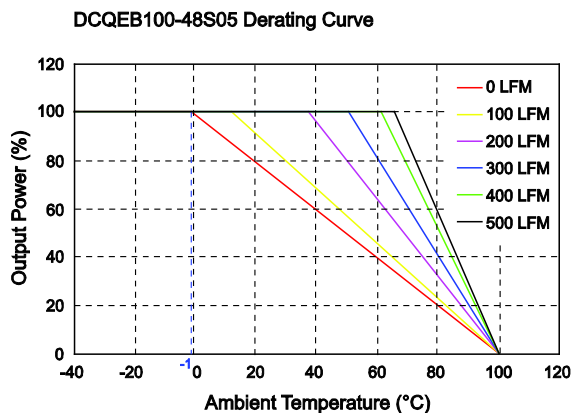

CHARACTERISTICS

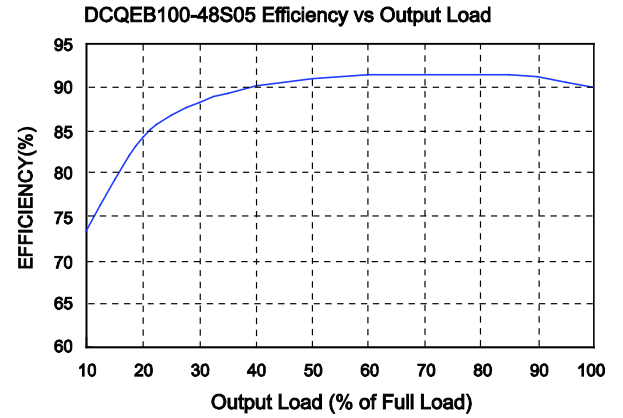
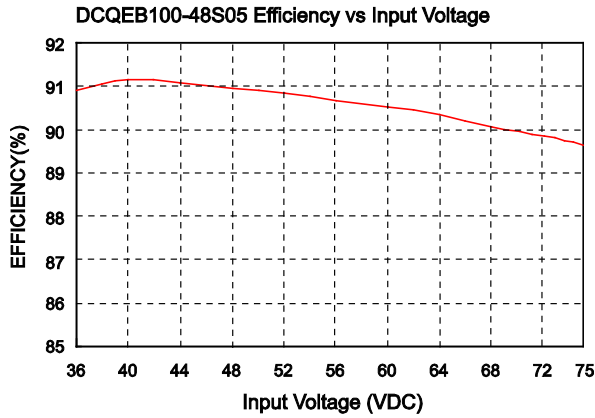

Recommended Filter for EN55022 Class B Compliance

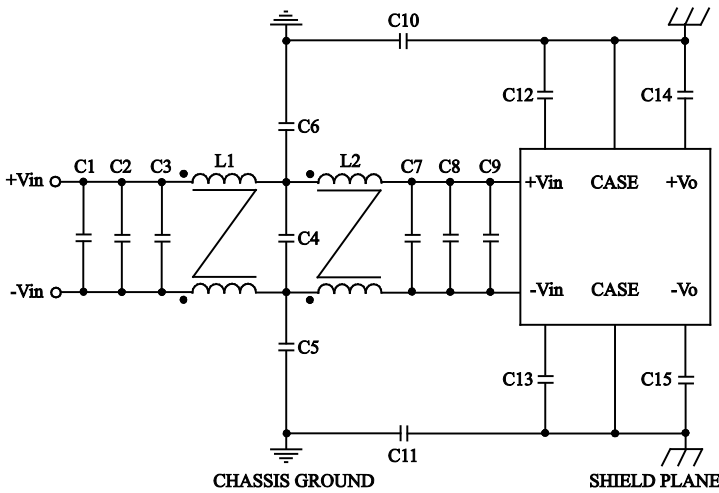

	C1	C2	C3	C4	C5
DCQEB100-24Sxx	685pF/50V	685pF/50V	685pF/50V	685pF/50V	1.5nF/3KV
	C6	C7	C8	C9	C10
	1.5nF/3KV	685pF/50V	685pF/50V	685pF/50V	0.1µF/50V
	C11	C12	C13	C14	C15
	0.1µF/50V	1.0nF/3KV	1.0nF/3KV	1.0nF/3KV	1.0nF/3KV
	L1	L2			
	1.37mH	1.37mH			

	C1	C2	C3	C4	C5
DCQEB100-48Sxx	100µF/100V	1.5µF/100V	1.5µF/100V	1.5µF/100V	1.5nF/3KV
	C6	C7	C8	C9	C10
	1.5nF/3KV	47µF/100V	1.5µF/100V	1.5µF/100V	0.1µF/50V
	C11	C12	C13	C14	C15
	0.1µF/50V	1.0nF/3KV	1.0nF/3KV	1.0nF/3KV	1.0nF/3KV
	L1	L2			
	620µH	620µH			

Recommended EN55022 Class B Filter Circuit Layout

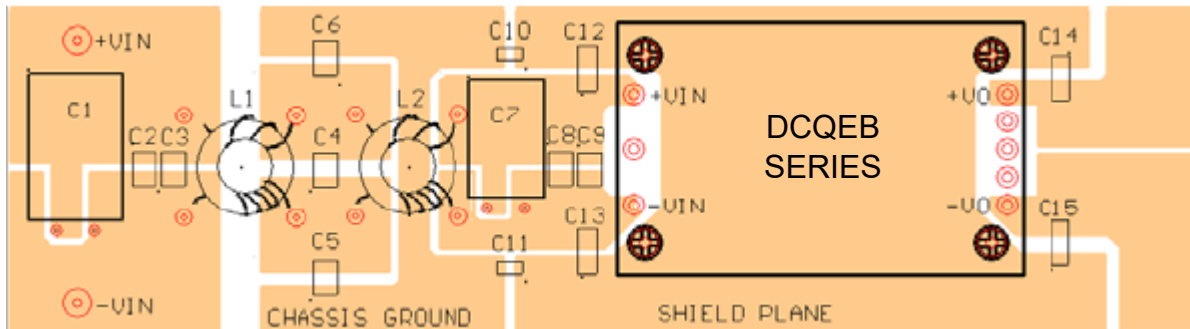

MECHANICAL DRAWING

Unit: inches (mm)

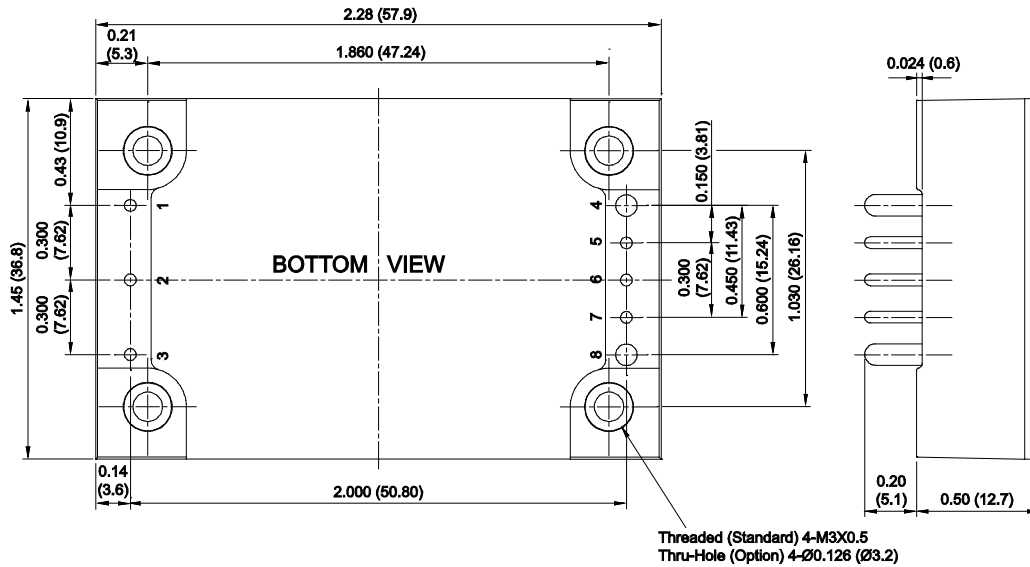

PIN CONNECTIONS		
PIN	FUNCTION	PIN \varnothing
1	-INPUT	\varnothing 0.040 (1.02)
2	CTRL	\varnothing 0.040 (1.02)
3	+INPUT	\varnothing 0.040 (1.02)
4	-OUTPUT	\varnothing 0.060 (1.52)
5	-SENSE	\varnothing 0.040 (1.02)
6	TRIM	\varnothing 0.060 (1.52)
7	+SENSE	\varnothing 0.040 (1.02)
8	+OUTPUT	\varnothing 0.060 (1.52)

1. Tolerance: X.XX \pm 0.02 (X.X \pm 0.5)
X.XXX \pm 0.01 (X.XX \pm 0.25)
2. Pin Pitch Tolerance: \pm 0.01 (\pm 0.25)
3. Pin Dimension Tolerance: \pm 0.004 (\pm 0.1)

PRODUCT OPTIONS		SUFFIX	PRODUCT OPTIONS		SUFFIX
Positive remote ON/OFF logic	0.200" pin length	none	Heatsinks	7G-0029A-F	H
	0.145" pin length	S		7G-0030A-F	H1
Negative remote ON/OFF logic	0.200" pin length	R		7G-0031A-F	H2
	0.145" pin length	RL		7G-0032A-F	H3
Thru-Hole Inserts ⁽¹⁾	\varnothing 0.126 (\varnothing 3.2) thru-hole (no thread) inserts	TH			
NOTES					
1. Models with thru-hole inserts cannot be equipped with a heatsink.					

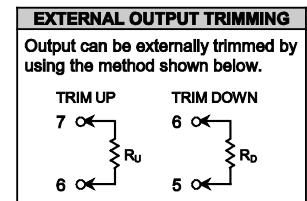

COMPANY INFORMATION

Wall Industries, Inc. has created custom and modified units for over 50 years. Our in-house research and development engineers will provide a solution that exceeds your performance requirements on-time and on budget. Our ISO9001 certification is just one example of our commitment to producing a high quality, well-documented product for our customers.

Our past projects demonstrate our commitment to you, our customer. Wall Industries, Inc. has a reputation for working closely with its customers to ensure each solution meets or exceeds form, fit and function requirements. We will continue to provide ongoing support for your project above and beyond the design and production phases. Give us a call today to discuss your future projects.

Contact **Wall Industries** for further information:

Phone: ☎(603)778-2300
Toll Free: ☎(888)597-9255
Fax: ☎(603)778-9797
E-mail: sales@wallindustries.com
Web: www.wallindustries.com
Address: 37 Industrial Drive
Exeter, NH 03833

©2019 Wall Industries, Inc. Specifications subject to change without notice. Wall Industries is not responsible for typographical errors. The information contained herein is for informational purposes only. This information is provided by Wall Industries and we make no representations or warranties of any kind, express or implied, about the completeness, accuracy, reliability, suitability or availability with respect to the information contained in this document for any purpose. All product and manufacturer names are trademarks or registered trademarks of their respective companies.