

FEATURES

- High Efficiency up to 86%
- Fixed Switching Frequency
- Six-Sided Continuous Shield
- 4:1 Wide Input Voltage Range
- International Safety Standard Approval
- **Call Factory for More Output Power Options**
- Options: Add suffix “-I” for Extended Operating Temperature Range
- Chassis Mount Options: Open Frame, U Channel, and Enclosed Types Available

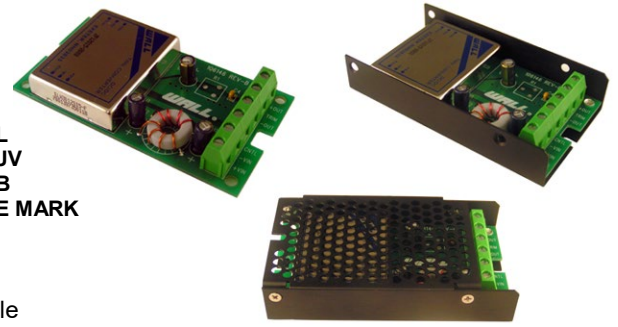

SPECIFICATIONS: CMJRW Series

All specifications apply @ 25°C ambient unless otherwise noted

INPUT SPECIFICATIONS

Input Voltage Range.....	24V nominal input	9 - 36VDC
	48V nominal input	18 - 75VDC
Input Surge Voltage (100ms max)	24V input.....	50VDC
	48V input.....	100VDC
Input Reflected Ripple Current30mA _{p-p} (nominal Vin and full load)	
Start Up Time (nominal Vin and constant resistive load).....	.20ms typ.	
Remote ON/OFF (Option) (See Note 2)		
(Positive Logic).....	DC-DC ON	Open or 3.5V < Vr < 12V
	DC-DC OFF	Short or 0V < Vr < 1.2V
(Negative Logic)	DC-DC ON	Short or 0V < Vr < 1.2V
	DC-DC OFF	Open or 3.5V < Vr < 12V
Remote Off Input Current (nominal Vin)20mA	

OUTPUT SPECIFICATIONS

Output Voltage	see table
Voltage Accuracy (nominal Vin and full load).....	±1%
Output Current	see table
Output Power	10 watts max.
Line Regulation (LL to HL at FL).....	±0.2%
Load Regulation (10% - 100 % FL).....	±0.5%
Minimum Load (See Note 1)	10% of full load
Ripple/Noise (20 MHz BW).....	.50mV _{p-p}
Temperature Coefficient.....	±0.02% / °C max.
Transient Response Recovery Time (25% load step).....	250us

PROTECTION SPECIFICATIONS

Over Voltage Protection	3.3V output.....	3.9V
(zener diode clamp)	5V output	6.2V
	12V output	15V
	15V output	18V
Over Load Protection (% of full load at nominal input)	150% max.	
Short Circuit Protection.	Hiccup, automatic recovery	

GENERAL SPECIFICATIONS

Efficiency	see table
Switching Frequency	300KHz typ.
Isolation Voltage (Input to Output).....	1600VDC min.
Isolation Resistance	10 ⁹ ohms min.
Isolation Capacitance.....	300pF max.

ENVIRONMENTAL SPECIFICATIONS

Operating Temperature (See derating curves)	
Standard	-25°C ~ +85°C (with derating)
“-I” (See Note 4).....	-40°C ~ +85°C (with derating)
Storage Temperature	-55°C ~ +105°C
Maximum Case Temperature	100°C
Relative Humidity	5% to 95% RH
Thermal Impedance (See Note 5)	
Natural Convection.....	12°C / Watt
Natural Convection with Heat-Sink	10°C / Watt
Thermal Shock.....	MIL-STD-810D
Vibration.....	10~55Hz, 10G, 30 minutes along X, Y, and Z
MTBF (See Note 3).....	1.976 x 10 ⁶ hours

PHYSICAL SPECIFICATIONS

Potting material of the DC/DC Converter.....	Epoxy (UL94-V0)
Shielding of the DC/DC Converter	six-sided
Weight	Approximately 6oz
Dimensions	4.00(L) x 2.25(W) x 0.81(H) inches

SAFETY & EMC

Approvals and Standards.....	IEC60950-1, UL60950-1 (See Note 10), EN60950-1	
Conducted Emissions	EN55022.....	Class A
Radiated Emissions	EN55022.....	Class A
	EN55022.....	Class B
ESD	EN61000-4-2	Perf. Criteria B
Radiated Immunity	EN61000-4-3	Perf. Criteria A
Fast Transient.....	EN61000-4-4	Perf. Criteria B
Surge	EN61000-4-5	Perf. Criteria B
Conducted Immunity	EN61000-4-6	Perf. Criteria A

Due to advances in technology, specifications subject to change without notice

OUTPUT VOLTAGE / CURRENT RATING CHART

Model Number	Input Range	Output Voltage	Output Current	Output Ripple & Noise	Input Current ⁽⁶⁾	Efficiency ⁽⁷⁾	Capacitor ⁽⁸⁾ Load max
CMJRW24S33-2500	24 VDC (9 – 36 VDC)	3.3 VDC	2500mA	50mVp-p	465mA	78%	6800µF
CMJRW24S5-2000		5 VDC	2000mA	50mVp-p	548mA	80%	4700µF
CMJRW24S12-830		12 VDC	830mA	50mVp-p	519mA	84%	690µF
CMJRW24S15-660		15 VDC	670mA	50mVp-p	544mA	81%	470µF
CMJRW48S33-2500	48 VDC (18 – 75 VDC)	3.3 VDC	2500mA	50mVp-p	239mA	76%	6800µF
CMJRW48S5-2000		5 VDC	2000mA	50mVp-p	270mA	81%	4700µF
CMJRW48S12-830		12 VDC	830mA	50mVp-p	259mA	84%	690µF
CMJRW48S15-660		15 VDC	670mA	50mVp-p	262mA	84%	470µF

NOTES

1. The CMJRW Series requires a minimum 10% loading on the output to maintain specified regulation. Operation under no-load condition will not damage these devices, however, they may not meet all listed specifications.
2. The ON/OFF control pin voltage is referenced to –Vin.
To order positive logic On/Off control add the suffix “-P” (Ex: CMJRW24S5-2000-P).
To order negative logic On/Off control add the suffix “-R” (Ex: CMJRW24S5-2000-R).
3. BELLCORE TR-NWT-000332. Case 1: 50% Stress, Temperature at 40°C. (Ground fixed and controlled environment).
4. “I” Version is more efficient; therefore, it can be operated over a more extensive temperature range than the standard version. Please add the suffix “-I” for industrial grade temperature range models.
5. Heat sink is optional, please consult factory for ordering details.
6. Maximum value at nominal input voltage and full load of standard type.
7. Typical value at nominal input voltage and no load.
8. Tested at minimum Vin and constant resistive load.
9. Chassis Mount Options: No suffix for open frame, “U” suffix for U Channel, and “E” suffix for Enclosed type.
10. This product is Listed to applicable standards and requirements by UL.

DERATING CURVE

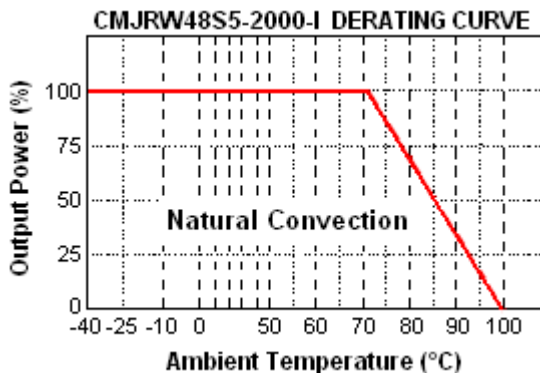

MECHANICAL DRAWING

Unit: inches [mm]

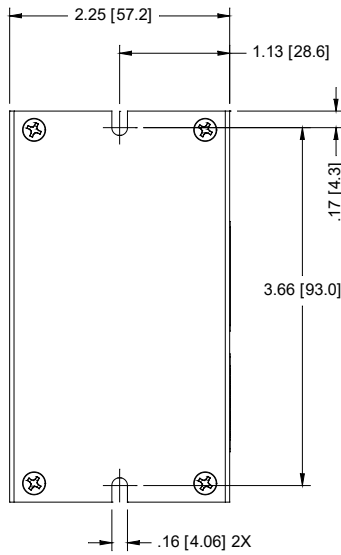
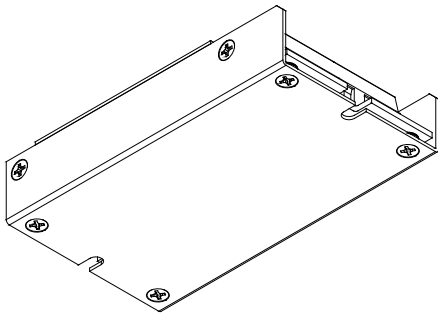
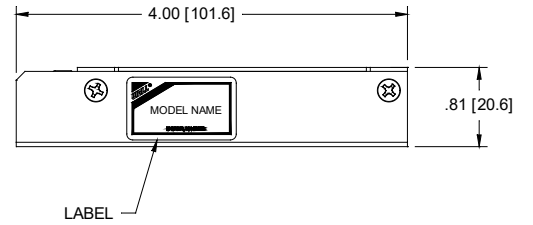
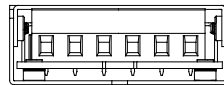
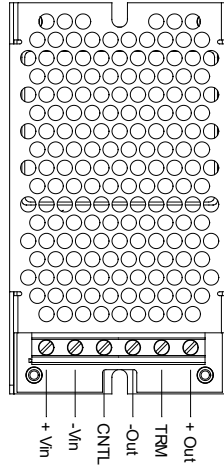
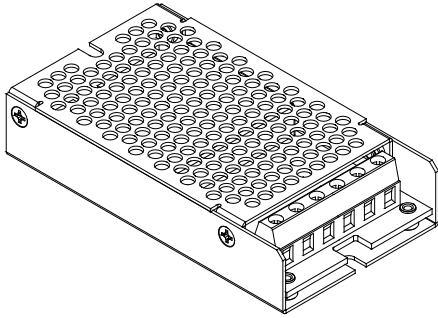

COMPANY INFORMATION

Wall Industries, Inc. has created custom and modified units for over 50 years. Our in-house research and development engineers will provide a solution that exceeds your performance requirements on-time and on budget. Our ISO9001 certification is just one example of our commitment to producing a high quality, well-documented product for our customers.

Our past projects demonstrate our commitment to you, our customer. Wall Industries, Inc. has a reputation for working closely with its customers to ensure each solution meets or exceeds form, fit and function requirements. We will continue to provide ongoing support for your project above and beyond the design and production phases. Give us a call today to discuss your future projects.

Contact **Wall Industries** for further information:

Phone: ☎ (603)778-2300
Toll Free: ☎ (888)597-9255
Fax: ☎ (603)778-9797
E-mail: sales@wallindustries.com
Web: www.wallindustries.com
Address: 37 Industrial Drive
Exeter, NH 03833

©2019 Wall Industries, Inc. Specifications subject to change without notice. Wall Industries is not responsible for typographical errors. The information contained herein is for informational purposes only. This information is provided by Wall Industries and we make no representations or warranties of any kind, express or implied, about the completeness, accuracy, reliability, suitability or availability with respect to the information contained in this document for any purpose. All product and manufacturer names are trademarks or registered trademarks of their respective companies.