

**FEATURES**

- RoHS Compliant
- Intelligent LED Indicators
- High Efficiency up to 90%
- +5V/0.5A Auxiliary Output
- Universal AC Input with Active PFC
- 1U Profile, High Power Density 11.1W / in<sup>3</sup>
- Power OK Signal (Power Good, Logic low)
- Remote On/Off and Remote Sense Function
- Forced Current Sharing at Parallel Operation
- Programmable Output Current (20% ~ 105%)
- Programmable Output Voltage (30% ~ 105%)
- Protection: OVP, OLP, OTP, SCP, Fan Failure



**DESCRIPTION**

The PSAK1000 series of AC/DC switching power supplies provides up to 1008 Watts of continuous output power in an enclosed design. All models have a single output and a universal input range with active PFC. Some features include efficiency up to 90%, 0.99 typical power factor, remote on/off, and forced current sharing at parallel operation. These supplies have over load, over voltage, over temperature, and short circuit protection.

<b>SPECIFICATIONS: PSAK1000 Series</b>	
All specifications are based on 25°C, Nominal Input Voltage, and Maximum Output Current unless otherwise noted. We reserve the right to change specifications based on technological advances.	
<b>INPUT SPECIFICATIONS</b>	
Input Voltage Range (See Note 3)	90 ~ 264VAC (127~370VDC)
Input Frequency	47 to 63Hz
AC Current (typical)	12A @ 115VAC; 5A @ 230VAC
Inrush Current (typical)	25A @ 115VAC; 54A @ 230VAC
Leakage Current	< 0.1mA @ 240VAC
Remote ON/OFF	External switch or NPN Transistor to turn ON/OFF
Power Factor (typical)	0.99 @ 115VAC and full load; 0.98 @ 230VAC and full load
<b>OUTPUT SPECIFICATIONS</b>	
Output Voltage	See Table
Output Power	See Table
Voltage Adjustment Range	±5.0% typical adjustment by potentiometer (VR1)
Voltage Tolerance (See Note 2)	±1.0%
Output Voltage Trim	Adjustment of output voltage is between 30%~100% of rated output.
Output Current Trim	Adjustment of output current is between 40%~105% of rated output.
Line Regulation	±0.5%
Load Regulation	±0.5%
Output Current	See Table
Ripple & Noise (See Note 1)	See Table
Setup, Rise Time	800ms, 60ms at full load
Hold-Up Time (typical)	16ms @ 230VAC and full load
<b>PROTECTION</b>	
Over Voltage Protection	See Table Protection Type: Latch-style (recovery after reset AC power ON or inhibit)
Over Load Protection	105% rated output power Protection Type: Total power limiting, Latch-style (recovery after reset AC power ON or inhibit)
Over Temperature Protection	By detecting primary and secondary heat sink. Protection Type: Shutdown output voltage (auto recovers after temperature goes down)
<b>GENERAL SPECIFICATIONS</b>	
Efficiency	See Table
Withstand Voltage	3KVAC (4242VDC) (input to output); 1.5KVAC (2121VDC) (input to FG); 0.5KVAC (707VDC) (output to FG)
Isolation Resistance	100MΩ/500VDC (input to output, input to FG, output to FG)
Auxiliary Power	5V @ 0.5A (±3%)
Power OK Signal	Open drain signal low when PSU turns on. Max sink current: 20mA, Max drain voltage: 40V.
Parallel Current Sharing (See Note 4)	Refer to Page 5
<b>ENVIRONMENTAL SPECIFICATIONS</b>	
Working Temperature	-25°C to +60°C (refer to derating curve)
Storage Temperature	-40°C to +85°C
Working Humidity	20% to 90% RH (non-condensing)
Storage Humidity	10% to 95% RH
Vibration	10-500Hz, 5G 10min/1cycle, period for 60 min. each along X, Y, Z axes Compliance to IEC 68-2-6, IEC 68-2-64
Cooling	Load and temperature control fan
Temperature Coefficient	±0.02% / °C (0 ~ 50°C)
<b>PHYSICAL SPECIFICATIONS</b>	
Packing	4.63 lbs (2.1kg)
Dimensions (See page 6)	11.14(L) x 5.00(W) x 1.61(H) inches; 283(L) x 127(W) x 40.9(H) mm
<b>SAFETY &amp; EMC (See Note 5)</b>	
Safety Standards	UL 60950-1, EN60950-1 approved
EMI Conduction & Radiation	Compliance to EN55022, EN 61000-6-3, -6-4
Power Harmonic & Voltage Fluctuation and Flicker	Compliance to EN61000-3-2, -3
EMS Immunity	Compliance to EN55024; EN 61204-3, EN 61000-6-1, ENV 50204, IEC 61000-4-2, 3, 4, 5, 6, 8, 11

**MODEL SELECTION TABLE**

Model Number	Input Voltage Range	Output Voltage	Output Current	Over Voltage Protection	Output Power	Ripple & Noise	Efficiency
PSAK-1000-12	90 ~ 264VAC (127 ~370VDC)	12 VDC	71A	13.8 ~ 15.0VDC	852W	150mVp-p	87%
PSAK-1000-15		15 VDC	57A	17 ~ 19.0VDC	855W	<1% <mvp-p< td=""> <td>88%</td> </mvp-p<>	88%
PSAK-1000-24		24 VDC	41A	27.6 ~ 30.0VDC	984W	<1% <mvp-p< td=""> <td>89%</td> </mvp-p<>	89%
PSAK-1000-27		27 VDC	37A	31 ~ 33.75VDC	999W	<1% <mvp-p< td=""> <td>89%</td> </mvp-p<>	89%
PSAK-1000-48		48 VDC	21A	55.2 ~ 60.0VDC	1008W	<1% <mvp-p< td=""> <td>90%</td> </mvp-p<>	90%

**NOTES**

1. Ripple & noise is measured at 20MHz bandwidth by using a 12" twisted pair-wire terminated with a 0.1µF capacitor and a 47µF capacitor in parallel.
  2. Tolerances include set up tolerance, line regulation, and load regulation.
  3. Derating is required under low input voltages. Please check the derating curve for more details.
  4. When in parallel connection only one unit might operate if the total output load is less than 5% of rated load condition.
  5. The power supply is considered a component, which will be installed into final equipment. The final equipment must be re-confirmed that it still meets EMC directives.
- Due to advances in technology, specifications are subject to change without notice.*

**DERATING CURVES**

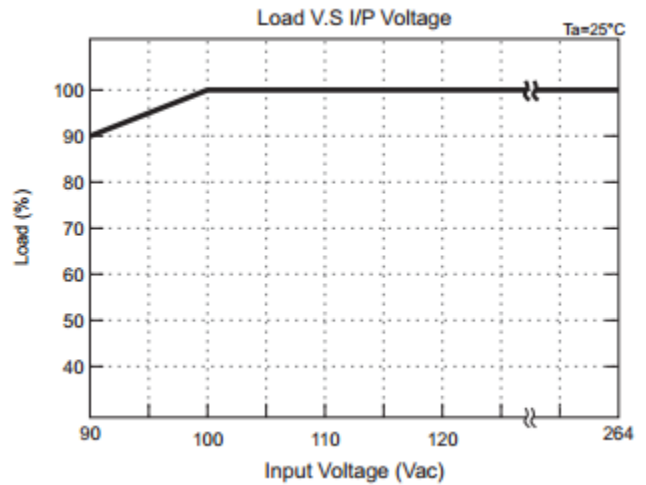
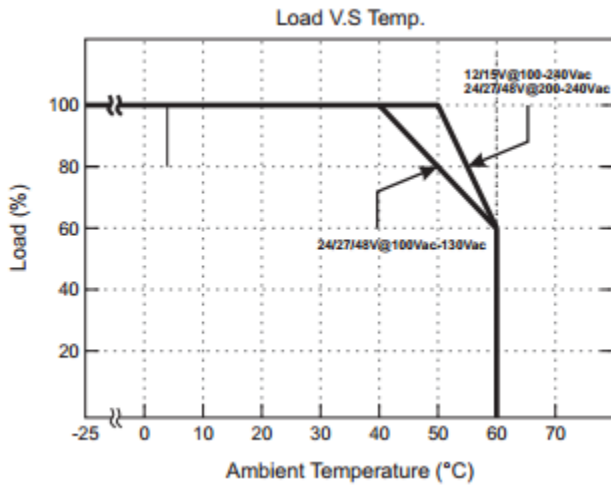

**FUNCTION MANUAL**

**1. OUTPUT VOLTAGE TRIM**

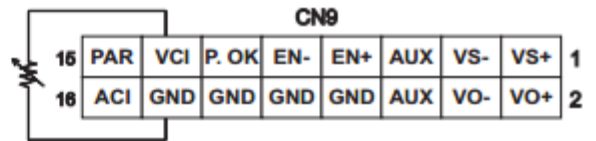
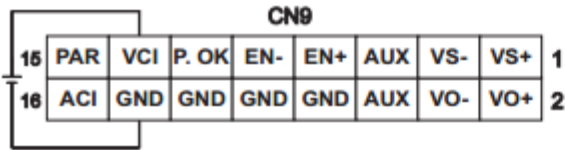
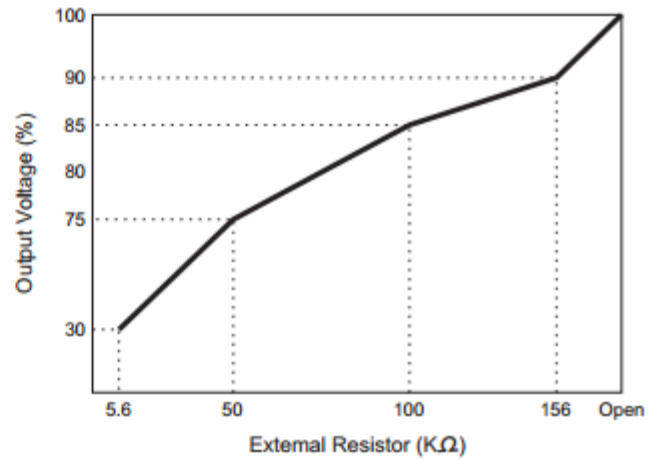
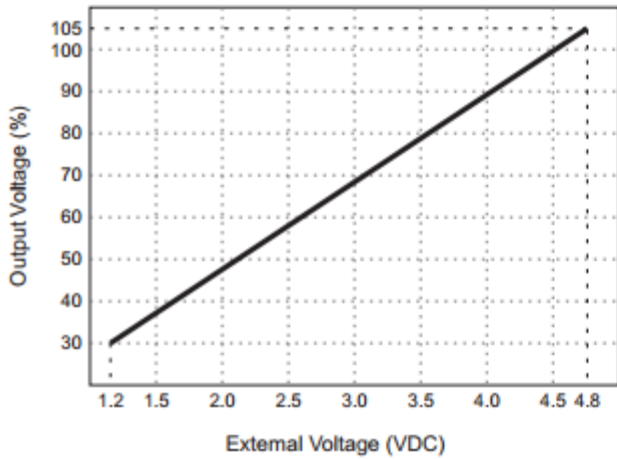

**2. OUTPUT CURRENT TRIM**

2. Output Current Trim (For Reference Only)

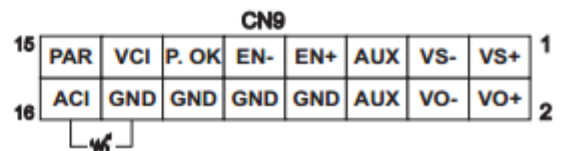
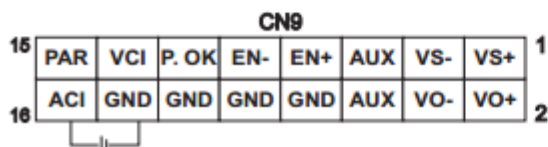
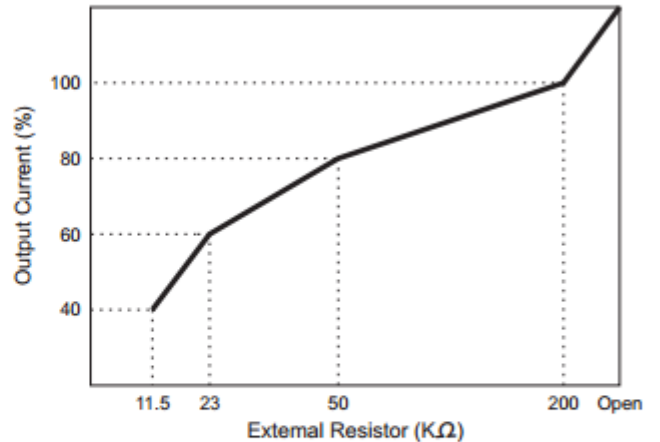
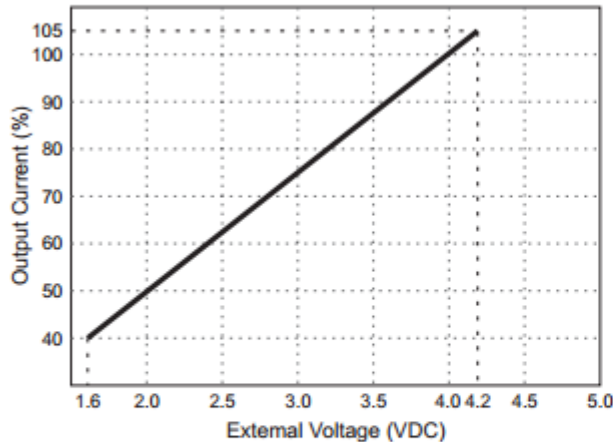

**3. REMOTE ON/OFF**

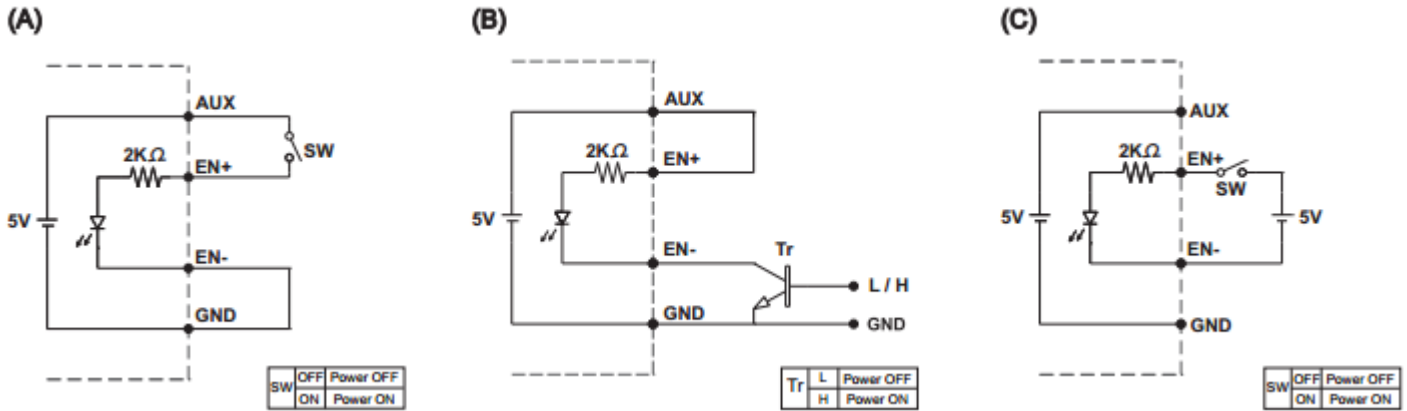

(A): Using internal 5V auxiliary source

(B): ON/OFF Control by NPN transistor

(C): Using external voltage source

**4. POWER OK SIGNAL**

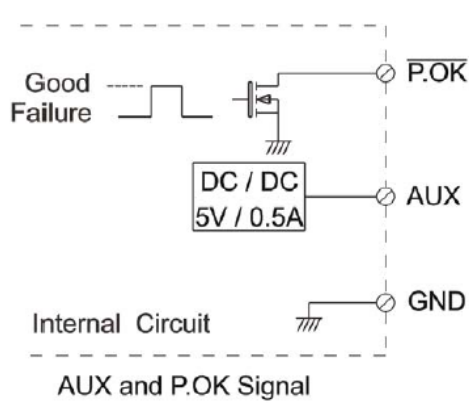

\*Place an additional capacitor to have a better performance of auxiliary power operation.

\*The grounding of "AUX" power should be connected to "GND" port. If "V-" is connected as Grounding, make sure to short the GND and V- ports.

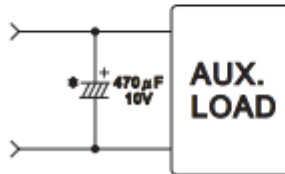

**5. REMOTE SENSE**

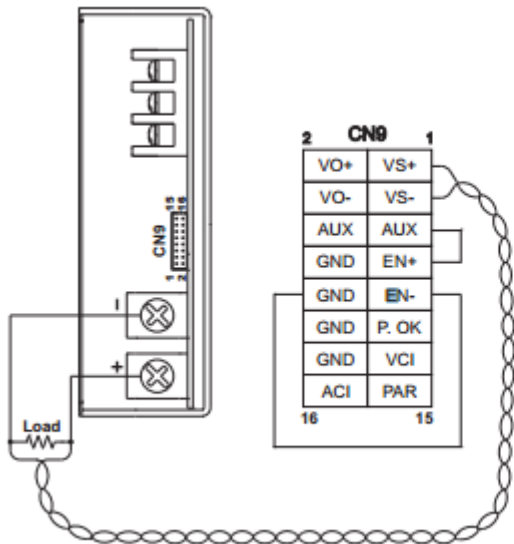

**6. LOCAL SENSE**

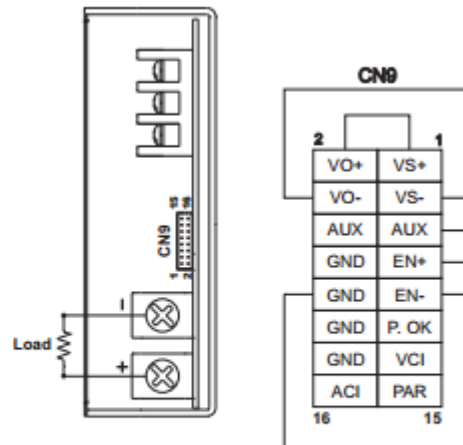

**7. CURRENT SHARING WITH REMOTE SENSING**

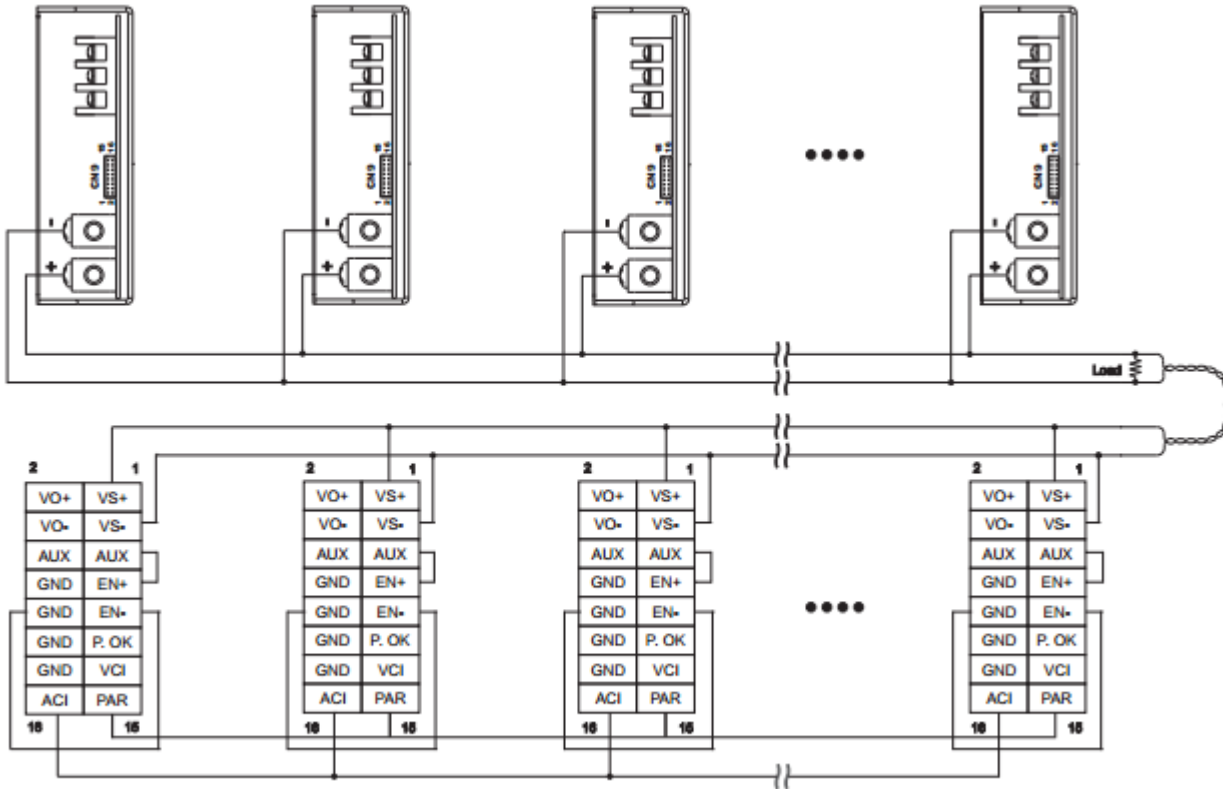

Please connect PAR pins together for current sharing function

**8. CURRENT SHARING WITH LOCAL SENSING**

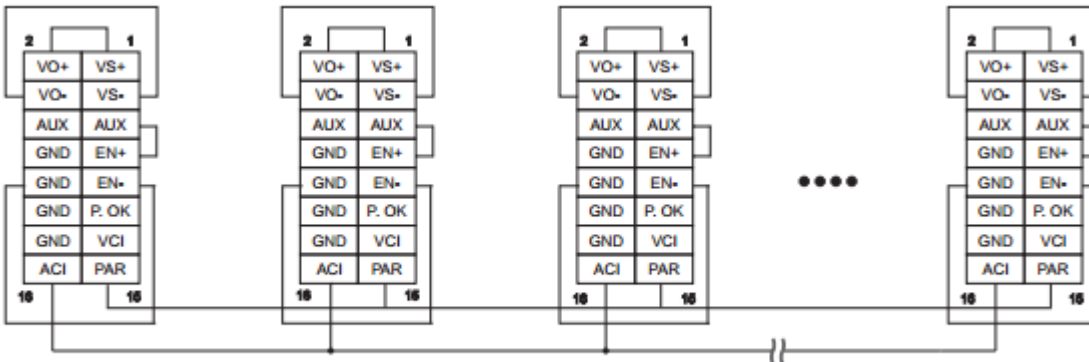

Please connect PAR pins together for current sharing function

**MECHANICAL DRAWING**

Unit: inches [mm]

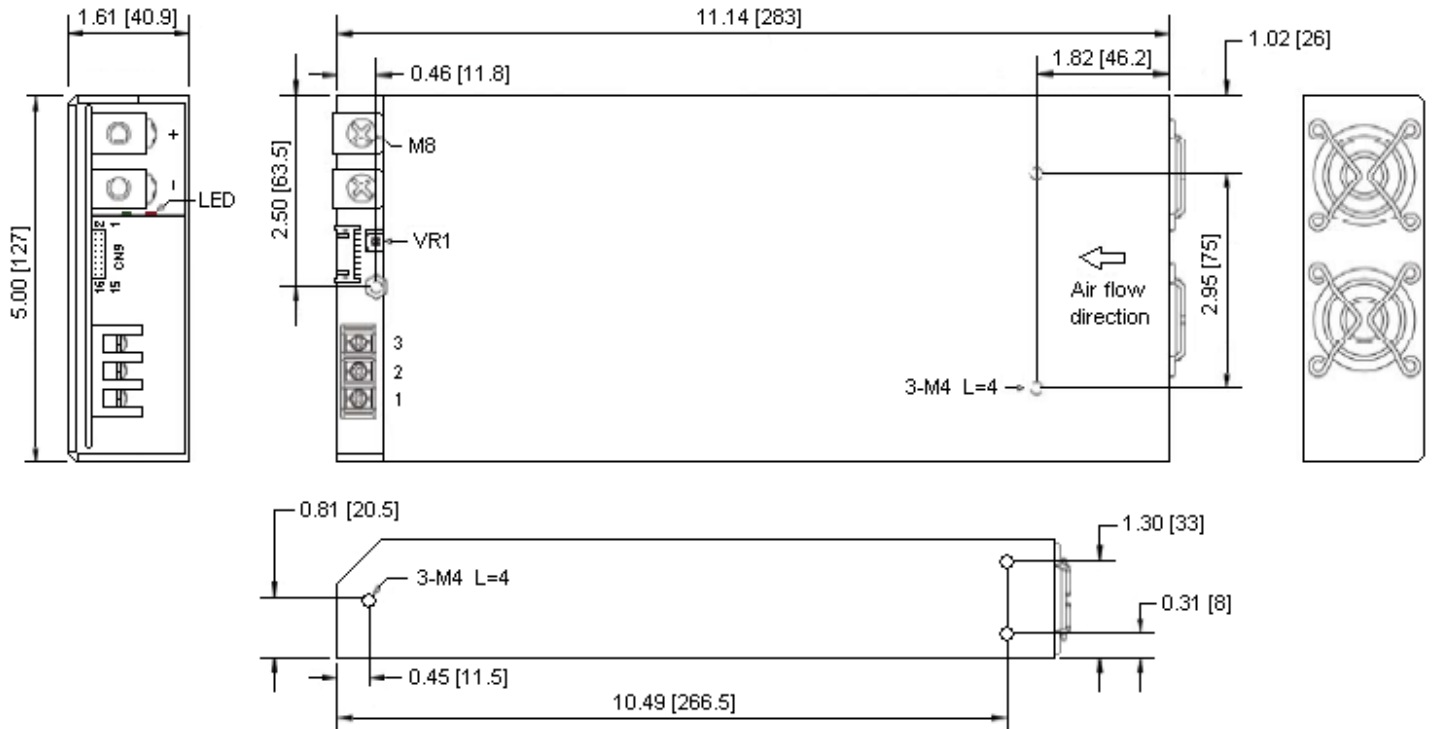

Recommended screw length is measured from the power supply surface

AC Input Terminal  
Pin No. Assignment







Control pin number assignment (CN9): JST S16B-PHDSS or equivalent

Pin No.	Assignment
1	ACL
2	ACN
3	⊥

Pin No.	Assignment	Pin No.	Assignment	Pin No.	Assignment	Pin No.	Assignment	Mating Housing	Terminal
1	VS+	5	AUX	9	EN-	13	VCI	PHDR-16VS	SPHD-002T-P05
2	VO+	6	AUX	10	GND	14	GND		
3	VS-	7	EN+	11	P.OK	15	PAR		
4	VO-	8	GND	12	GND	16	ACI		

Pin No.	Function	Description
1	VS+	Remote voltage sense (+)
2	VO+	Local output voltage sense (+)
3	VS-	Remote voltage sense (-)
4	VO-	Local output voltage sense (-)
5,6	AUX	+5V / 0.5A Auxiliary power
7	EN+	Remote ON/OFF (+)
8,10,12,14	GND	Ground
9	EN-	Remote ON/OFF (-)
11	P.OK	Power OK
13	VCI	V Program
15	PAR	Parallel operation current share
16	ACI	I Program

**LED STATUS**

Green LED	LED Signal	Status
Solid		Power OK
Slow Blink		Power Standby
Red LED	LED Signal	Status
Fast Blink		Over Voltage Protection (OVP)
Solid		Over Load Protection (OLP)
		Output Short Circuit Protection (SCP)
		Under Voltage Protection (UVP)
		Over Temperature Protection (OTP)
Slow Blink		Fan Failure
Intermittent link		Fan Failure
Interlace Blink		Power Failure

**INSTALLATION INSTRUCTIONS**

1. Mounting Directions

1-1 Recommended standard mounting methods:

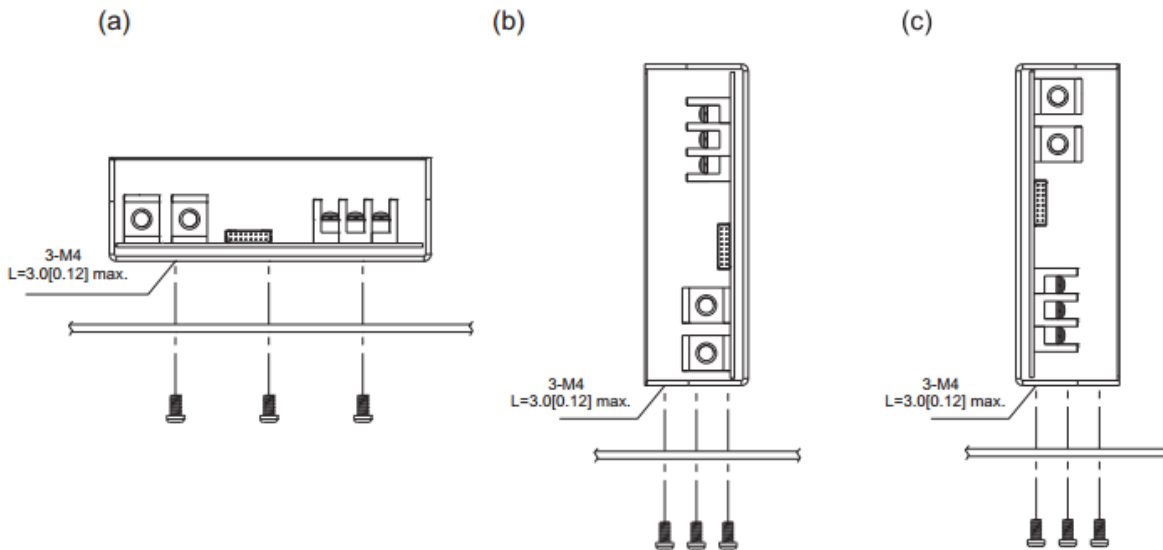

Recommended screw length is measured from the power supply surface

2. Mounting Method

2-1 There are ventilating holes on the front and back side panels, do not obstruct; allow 50mm at least for air flow.

2-2 The Maximum allowable penetration of screw is 4mm. Incomplete threading should not be penetrated.

2-3 Recommended the torque of mounting screw:  
 M4 screw: 1.27N • m (13.0kgf • cm)

