

FEATURES

- Single Output
- 20 Watts Output Power
- High Efficiency up to 87%
- Fixed Switching Frequency
- Six-Sided Continuous Shield
- 2:1 and 4:1 Wide Input Voltage Range
- ISO9001 Certified Manufacturing Facilities
- **Call Factory for More Output Power Options**
- Compliant to RoHS EU Directive 2002/95/EC
- UL60950-1, EN60950-1, and IEC60950-1 Licensed
- CE Mark meets 2006/95/EC, 93/68/EEC, and 89/336 EEC
- Chassis Mount Options: Open Frame, U Channel, and Enclosed Types Available

APPLICATIONS

- Measurement
- Wireless Network
- Telecom/Datacom
- Industry Control System
- Semiconductor Equipment

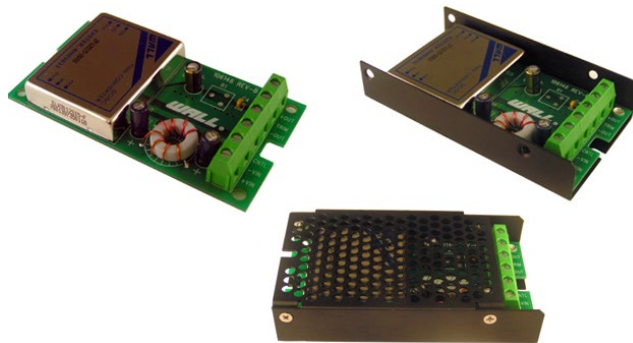

SPECIFICATIONS: CMYF/YFW Series

All specifications apply @ 25°C ambient unless otherwise noted

INPUT SPECIFICATIONS

Input Voltage Range		
CMYF	12V nominal input	9-18VDC
	24V nominal input	18-36VDC
	48V nominal input	36-75VDC
CMYFW	24V nominal input	9-36VDC
	48V nominal input	18-75VDC
Input Surge Voltage (100ms max)	12V input	36VDC
	24V input	50VDC
	48V input	100VDC
Input Reflected Ripple Current (nominal Vin and full load)		25mA _{p-p}
Start Up Time (nominal Vin and constant resistive load)		20ms typ.
Remote ON/OFF (See Note 7)		
(Positive Logic)	DC-DC ON	Open or 3.5V < Vr < 12V
	DC-DC OFF	Short or 0V < Vr < 1.2V
Input Current of Remote Control Pin (nominal Vin)		-0.5mA ~ 1.0mA
Remote Off State Input Current (nominal Vin)		20mA

OUTPUT SPECIFICATIONS

Output Voltage	see table
Voltage Accuracy (nominal Vin and full load)	±1%
Voltage Adjustability	±10%
Output Current	see table
Output Power	20 watts max.
Line Regulation (LL to HL at FL)	±0.2%
Load Regulation (no load to full load)	±0.5%
Minimum Load (See Note 6)	see table
Ripple/Noise (20 MHz BW)	75mV _{p-p}
Transient Response Recovery Time	250us
(25% load step)	

PROTECTION SPECIFICATIONS

Over Voltage Protection	3.3V Output	3.9V
Zener diode clamp	5V Output	6.2V
	12V Output	15V
	15V Output	18V
Over Load Protection (% of full load at nominal input)		150% max.
Short Circuit Protection		Hiccup, automatic recovery

GENERAL SPECIFICATIONS

Efficiency	see table
Switching Frequency	300KHz typ.
Isolation Voltage (Input to Output)	1600VDC min.
Isolation Resistance	10 ⁹ ohms min.
Isolation Capacitance	300pF max.

ENVIRONMENTAL SPECIFICATIONS

Operating Temperature	-40°C to +85°C (with derating)
Storage Temperature	-55°C ~ +105°C
Maximum Case Temperature	+100°C
Relative Humidity (non-condensing)	5% to 95% RH
Temperature Coefficient	±0.02% / °C max.
Thermal Impedance (See Note 8)	
Natural Convection	10°C / Watt
Natural Convection with Heat-Sink	8.24°C/Watt
Thermal Shock	MIL-STD-810F
Vibration	10~55Hz, 10G, 30 minutes along X, Y, and Z
MTBF (See Note 1)	1.928 x 10 ⁶ hrs

PHYSICAL SPECIFICATIONS

Potting material of the DC/DC converter	Epoxy (UL94-V0)
Shielding of the DC/DC converter	six – sided
Weight	Approximately 7oz
Dimensions	4(L) x 2.2(W) x 0.81(H) inches

SAFETY & EMC

Approvals and Standards	IEC60950-1, UL60950-1 (See Note 11),	EN60950-1
EMI	EN55022	Class A
ESD	EN61000-4-2	Air ± 8KV
		Contact ± 6KV
Radiated Immunity	EN61000-4-3	10V/m Perf. Criteria A
Fast Transient	EN61000-4-4	±2KV Perf. Criteria B
Surge	EN61000-4-5	±1KV Perf. Criteria B
Conducted Immunity	EN61000-4-6	10 Vrms Perf. Criteria A

Due to advances in technology, specifications subject to change without notice

OUTPUT VOLTAGE / CURRENT RATING CHART

Model Number	Input Range	Output Voltage	Output Current		Output ⁽⁴⁾ Ripple & Noise	Input Current		Eff. ⁽⁴⁾	Capacitor ⁽⁵⁾ Load max
			Min. load	Full load		No load ⁽³⁾	Full load ⁽²⁾		
CMYF12S33-4000	9 - 18 VDC	3.3 VDC	280mA	4000mA	75mVp-p	40mA	1507mA	77%	13000uF
CMYF12S5-4000		5 VDC	280mA	4000mA	75mVp-p	15mA	2193mA	80%	6800uF
CMYF12S12-1600		12 VDC	134mA	1670mA	75mVp-p	40mA	2110mA	83%	2200uF
CMYF12S15-1330		15 VDC	106mA	1330mA	75mVp-p	20mA	2083mA	84%	755uF
CMYF(W)24S33-4000	18 - 36 VDC (9 - 36 VDC)	3.3 VDC	280mA	4000mA	75mVp-p	10 (20)mA	733 (764mA)	79 (76) %	13000uF
CMYF(W)24S5-4000		5 VDC	280mA	4000mA	75mVp-p	10 (10)mA	1082 (1111mA)	81 (79) %	6800uF
CMYF(W)24S12-1600		12 VDC	134mA	1670mA	75mVp-p	10 (20)mA	1018 (1082mA)	86 (81) %	2200uF
CMYF(W)24S15-1330		15 VDC	106mA	1330mA	75mVp-p	15 (20)mA	1018 (1082mA)	86 (81) %	755uF
CMYF(W)48S33-4000	36 - 75 VDC (18 - 75 VDC)	3.3 VDC	280mA	4000mA	75mVp-p	10 (15)mA	367 (377mA)	79 (77) %	13000uF
CMYF(W)48S5-4000		5 VDC	280mA	4000mA	75mVp-p	10 (10)mA	543 (548mA)	82 (80) %	6800uF
CMYF(W)48S12-1600		12 VDC	134mA	1670mA	75mVp-p	15 (10)mA	509 (536mA)	86 (82) %	2200uF
CMYF(W)48S15-1330		15 VDC	106mA	1330mA	75mVp-p	25 (10)mA	506 (532mA)	86 (82) %	755uF

NOTES

- BELLCORE TR-NWT-000332. Case I: 50% Stress, Temperature at 40°C. (Ground fixed and controlled environment).
- Maximum value at nominal input voltage and full load.
- Typical value at nominal input voltage and no load.
- Typical value at nominal input voltage and full load.
- Test by minimum Vin and constant resistive load.
- The output requires a minimum loading on the output to maintain specified regulation. Operation under no-load condition will not damage these devices, however they may not meet all listed specifications.
- The ON/OFF control pin voltage is referenced to -Vin.
- Heat sink is optional (for operation temperature range please see derating curve). Contact Factory for ordering details.
- The CMYF Series is 2:1 wide input range of 18-36VDC and 36-75VDC; the CMYFW Series is 4:1 ultra wide input range of 9-36VDC and 18-75VDC.
- Chassis Mount Options: No suffix for open frame, "U" suffix for U Channel, and "E" suffix for Enclosed type.
- This product is Listed to applicable standards and requirements by UL.

DERATING CURVES & EFFICIENCY GRAPHS

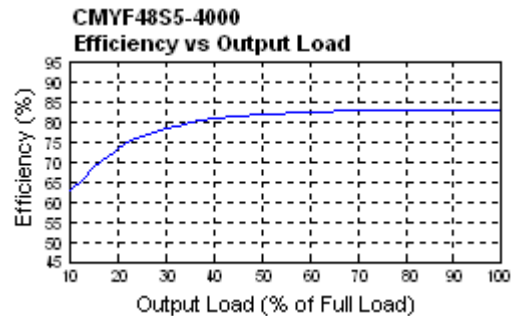
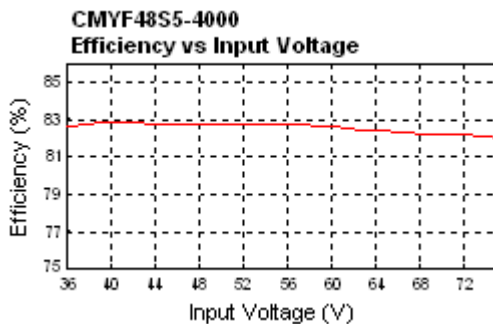
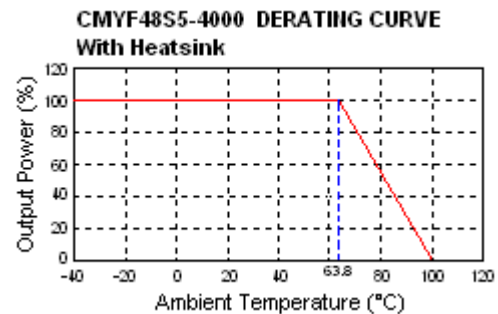
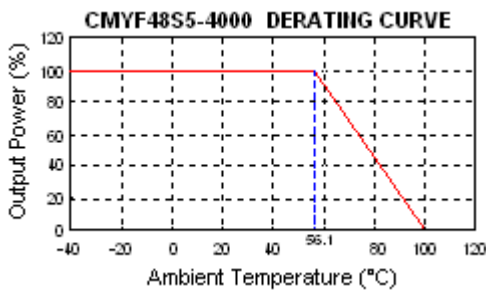

MECHANICAL DRAWING

Unit: inches [mm]

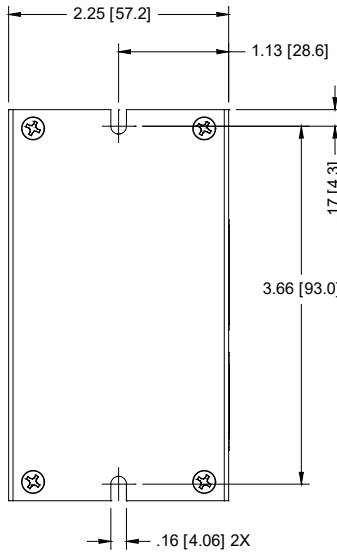
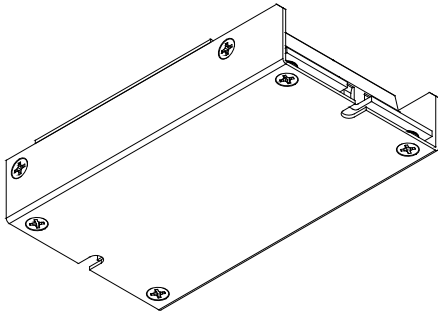
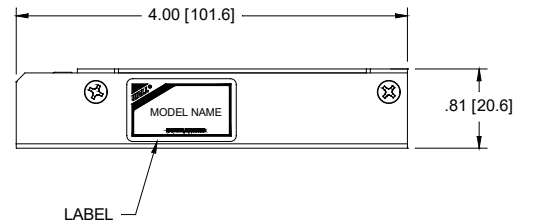
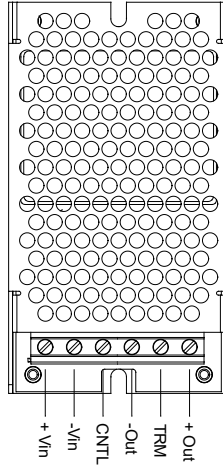
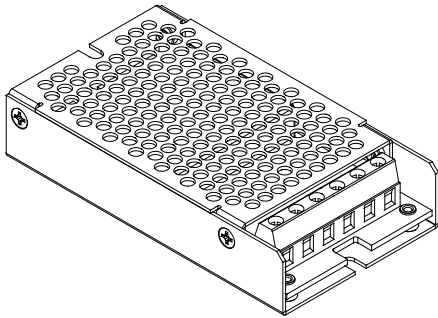



COMPANY INFORMATION

Wall Industries, Inc. has created custom and modified units for over 50 years. Our in-house research and development engineers will provide a solution that exceeds your performance requirements on-time and on budget. Our ISO9001 certification is just one example of our commitment to producing a high quality, well-documented product for our customers.

Our past projects demonstrate our commitment to you, our customer. Wall Industries, Inc. has a reputation for working closely with its customers to ensure each solution meets or exceeds form, fit and function requirements. We will continue to provide ongoing support for your project above and beyond the design and production phases. Give us a call today to discuss your future projects.

Contact **Wall Industries** for further information:

Phone: ☎(603)778-2300
Toll Free: ☎(888)597-9255
Fax: ☎(603)778-9797
E-mail: sales@wallindustries.com
Web: www.wallindustries.com
Address: 37 Industrial Drive
Exeter, NH 03833

©2019 Wall Industries, Inc. Specifications subject to change without notice. Wall Industries is not responsible for typographical errors. The information contained herein is for informational purposes only. This information is provided by Wall Industries and we make no representations or warranties of any kind, express or implied, about the completeness, accuracy, reliability, suitability or availability with respect to the information contained in this document for any purpose. All product and manufacturer names are trademarks or registered trademarks of their respective companies.