

Wall Industries, Inc.

FA12S15-300

300W DC-DC Converter
10-36 Vdc Input
15Vdc Output at 20A
Full-Brick Package



Features:

- **88% Efficient at Full Load**
- **90% Efficiency at 1/2 Load**
- **Fast Transient Response**
- **Operation to No Load**
- **Output Trim $\pm 10\%$**
- **Remote ON/OFF (Active High/Low)**
- **Remote Sense Compensation**
- **Delivers a Continuous 150W at 25°C with No Air / No Heatsink**
- **Very Low Output Ripple**
- **Fixed Switching Frequency**
- **Output Over Current Foldback**
- **Output Short Circuit Protection**
- **Over Temperature Protection**
- **1500 V Isolation**
- **100% Burn In**
- **Synchronizable**

Description:

The FA series is a high-density full brick converter that incorporates the desired features required in today's demanding low voltage bus applications. Its unique dual interleaved phase-shifted topology minimizes both input and output noise. When performance, reliability, and low cost are needed, the FA series delivers.

Technical Specifications		Model No.	FA12S15-300			
<p>All specifications are based on 25°C, Nominal Input Voltage, and Maximum Output Current unless otherwise noted. We reserve the right to change specifications based on technological advances.</p>						
SPECIFICATION	Related condition	Min	Nom	Max	Unit	
Switching Frequency		-	600	-	KHZ	
INPUT (V_{in})						
Operating Voltage Range		10	12	36	Vdc	
UVLO Turn On at		9.5	9.7	10	Vdc	
UVLO Turn Off at		9.0	9.25	9.5	Vdc	
UVLO Hysteresis		-	0.5	-	Vdc	
Maximum Input Current (Graph 3)	Low Line	-	34.7	-	A	
No Load Input Current (Graph 3)	No Load	-	0.10	-	A	
Input Current under "Remote Off"		-	1	-	mA	
Reflected Ripple Current	With L-C filter as shown in Fig. 7.	-	20	-	mA	
Input Surge Voltage	100 mS	-	-	50	Vdc	
EFFICIENCY (Graph 1)	I _o =20A	-	86	-	%	
OUTPUT (V_o)						
Voltage Set Point	±Sense shorted to ±V _{out}	14.85 -1%	15.00	15.15 +1%	Vdc %	
Voltage Adjustment (Table 1)	Max Output limited to 300W	13.5 -10%		16.5 +10%	Vdc	
Load Regulation	±Sense shorted to ±V _{out}	-	0.05	0.2	%	
Line Regulation	±Sense shorted to ±V _{out}	-	0.05	0.2	%	
Temperature Drift		-	0.01	0.02	% / °C	
Remote Sense Compensation	Max Output limited to 300W (max. drop in each + and - output trace)	-	-	1	Vdc	
Ripple (Photo 4,5,6)	0.1µF Ceramic & 10µF Tantalum	-	50	150	mV p-p	
Spikes (Photo 4,5,6)	0.1µF Ceramic & 10µF Tantalum	-	50	150	mV p-p	
Current	Rated maximum output current	0	-	20	A	
Current Limit	Power Limited-Dependent upon SENSE compensation and TRIM adjustment	-	26.0	-	A	
Over Voltage Limit		17	19	21	Vdc	
DYNAMIC RESPONSE						
Load step / ΔV (Photo 7)	50% to 100% I _o	-	1	-	V	
Recovery Time (Photo 7)	Recovery to within 1% Nominal V _{out}	-	0.4	-	mS	
Turn On Delay (Photo 1)	From V _{in} (min) to V _{out} (nom)	-	50	-	mS	
Turn On Overshoot (Photo 1,2)	Full Load Resistive	-	0.0	-	%	
Hold Up Time (Photo 3)		0	-	-	mS	
REMOTE ON/OFF Active High or Active Low (See page 14 for ordering details)						
Remote ON – Positive logic	TTL high or Open-circuit	2.5	-	5.0	Vdc	
Remote OFF – Positive logic	TTL Low	-	-	2.0	Vdc	
Remote ON pin Floating - Positive logic	Over Operating Voltage Range	4.4	-	5.0	Vdc	
I _{ON/OFF} Sink current - Positive logic	V _{ON/OFF} =0V, V _{in} =75V	-	-	1.0	mA	
Remote ON – Negative logic	Max Low to Enable	-	-	2.0	Vdc	
Remote OFF – Negative logic	Min High to Disable	2.5	-	5.0	Vdc	
Remote ON/OFF pin Floating – Negative logic	Over Operating Voltage Range	4.4	-	4.7	Vdc	
I _{ON/OFF} Sink to pull low – Negative logic	V _{ON/OFF} =0V, V _{in} =75V	-	-	1	mA	
I _{ON/OFF} Source to drive high – Active High or Low		-	-	1	µA	
Turn On Delay – (Photo 2)	Enabled	-	50	-	mS	
Turn Off Delay – (Photo 3)	Disabled	-	-	10	µS	
ISOLATION						
Input-Output	1 minute	1500	-	-	Vdc	
Isolation Resistance		1	-	-	GΩ	
Isolation Capacitance		-	0.010	-	µF	
THERMAL						
Ambient (Graph 2)	Max. Ambient limited by Derating Curves (Graph 2)	-40	25	Graph 2	°C	
Over Temperature Protection	Self Resetting	-	110	-	°C	
Storage Temperature	Ambient	-55	-	125	°C	
MTBF	Calculated Using Bellcore TR-332 Method 1 case 3		2,212,456		Hours	
MECHANICAL						
Weight		-	318	-	g	

Figure 1: Mechanical Dimensions

Unit: inches [mm]

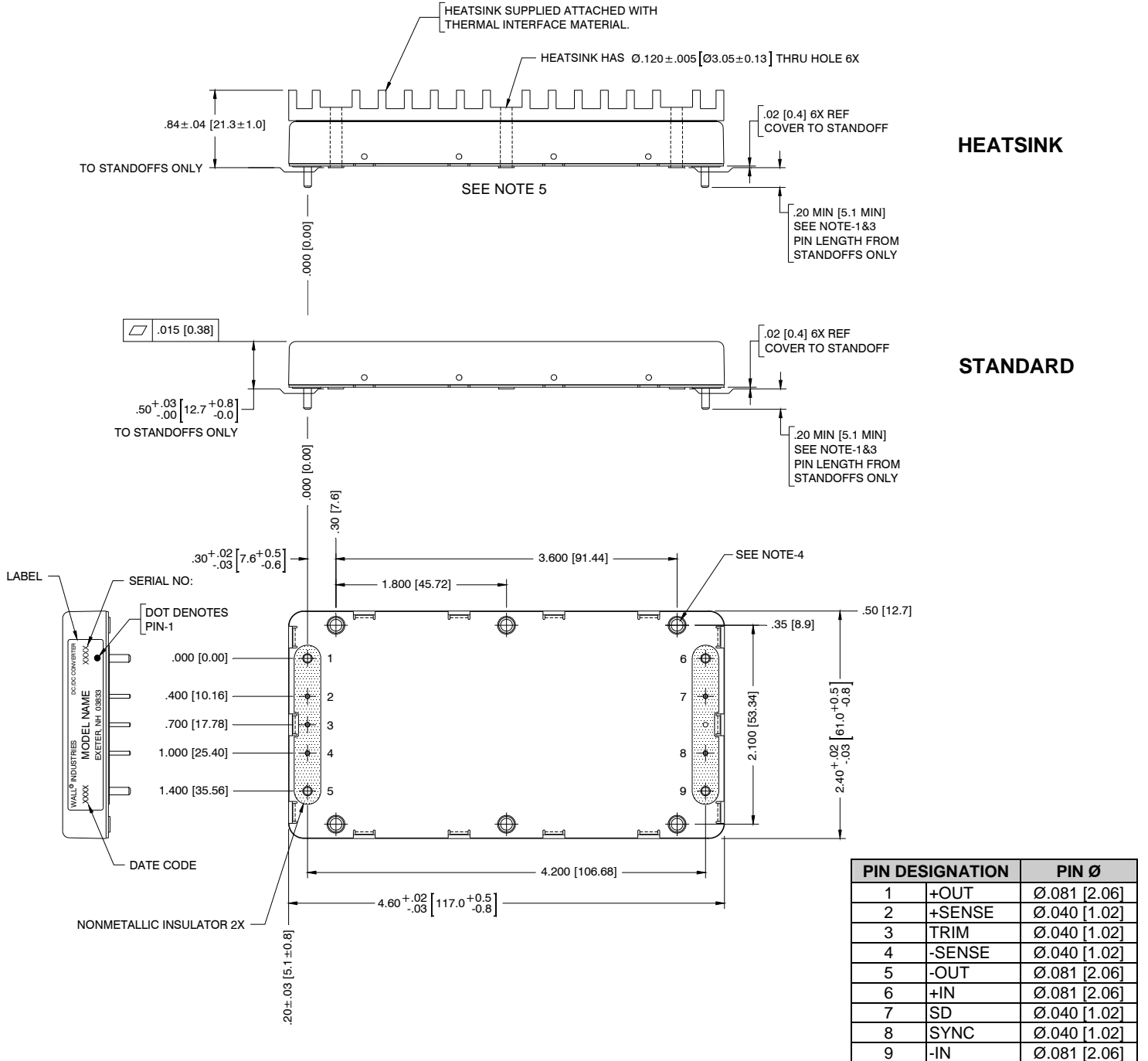

NOTES:

- PIN TO PIN TOLERANCE $\pm .01$ [± 0.3], PIN DIAMETER TOLERANCE: $\pm .005$ [± 0.13].
- CASE MATERIAL: .040 [1.02] THICK, ALUMINUM ALLOY 3003-0, PER: QQA 250/2.
- UNLESS OTHERWISE SPECIFIED.

TO ORDER:

- UNIT COMES WITH EITHER 3M x 0.5 THREADED THRU INSERTS OR FOR $\varnothing.125$ THRU-HOLE ADD: "TH" SUFFIX TO MODEL PART NUMBER. EXAMPLE: FA12S5-300TH
- FOR HEAT SINK ADD: "HS" SUFFIX TO MODEL PART NUMBER. EXAMPLE: FA12S5-300HS.
- OPTIONAL CHASSIS MOUNT VERSION AVAILABLE (SEE CMFA SERIES).

DESIGN CONSIDERATIONS

Under Voltage Lock Out (UVLO)

The converter output is disabled until the input voltage exceeds the UVLO turn-on limit. The converter will remain ON until the input voltage falls below the UVLO turn-off limit. There is approximately 0.5V hysteresis in the UVLO circuit.

Over Current Protection

The converter is internally protected from short circuit and over current conditions. During these fault conditions, the converter output will “hiccup”- (short) or “fold back” - (over current). The converter output will recover once the short or over current fault is removed.

Over Temperature Protection

The converter is protected from over temperature conditions. Upon exceeding this temperature, the converter will shut down. The converter will automatically recover once it has sufficiently cooled.

Input Filter

A 1,000 μ F low ESR capacitor across the input pins is recommended for most system level designs. No additional input capacitance is needed for the power supply to operate with low impedance inputs. However, most “real world” system level integration will have some amount of trace or wiring lengths – raising the inductive impedance. The added input capacitor will bring the impedance back towards unity.

Output Filter

No additional output capacitor is needed for the power supply to operate within stated specifications. However, if it is a requirement to reduce the ripple and noise on the output, additional capacitance may be added. Usually, ceramic MLCC’s capacitor works best for reducing H.F. spike noise. Also, capacitance in the form of a tantalum or aluminum electrolytic capacitor may also be placed across the output in order reduce base ripple, and improve the load transient peak-to-peak voltage deviation.

Remote Sense

To improve the voltage regulation at the load, route the connections from the -Sense and the +Sense pins to the -Vout and +Vout connections AT the load. This will force the converter to regulate the voltage at the load and not at the pins of the converter. If it is not desired to use the Remotes Sense feature, the -Sense and +Sense pins should be connected to the -Vout and +Vout pins respectively.

Fusing

It is required that the input to the converter be supplied with a maximum 50 A, 250 V rated fuse.

Safety

The FA series is CE pending and pending approval of the following: UL1950, CUL950, TUV60950 FILE 155800. The isolation provided by the FA Series is a Basic insulation in accordance with EN60950. SELV output reliability is maintained only if the input to the FA converter is an SELV source.

Remote ON/OFF

The FA Series has Remote ON/OFF (Enable/Disable) capability using TTL logic levels. This function is offered as either Active=TTL High (no suffix) or Active=TTL Low (R suffix), see order details on page 14. For Remote ON/OFF limits, see page 2.

Figure 2. Remote (L/E)

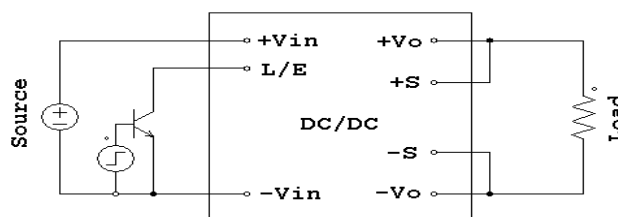

Synchronization

The FA series provides synchronization of switching frequencies between multiple FA series power supplies. The synchronization function is accomplished without the need for any added external circuitry. By tying the SYNC pin between FA modules, they will all automatically synchronize. If synchronization is not used, the pin should be tied to $-V_{in}$.

Output Voltage Trim

The following information is provided to allow quick calculation of the trim resistor value for a desired output voltage. The general procedure for calculating a trim resistor is as follows:

1. Determine the desired output voltage deviation %.
2. To trim down, solve for resistor value using the "Rtlow" equation.
3. To trim up, solve for resistor value using the "Rthi" equation.
4. Solved resistor values are in $K\Omega$.

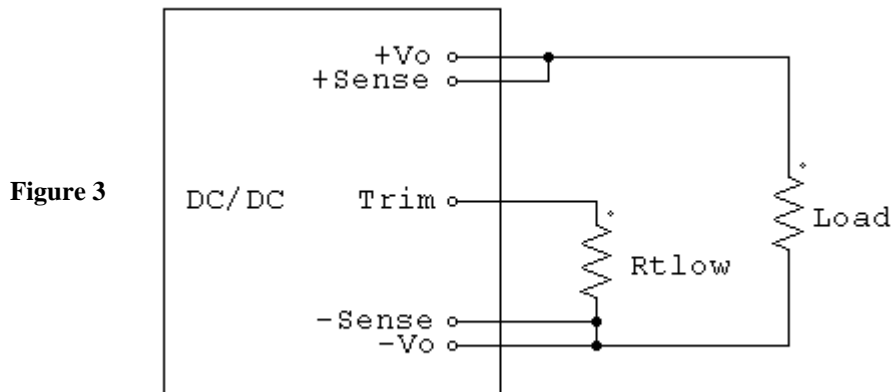

$$R_{tlow} = \left(\frac{510}{\Delta\%} - 10.2 \right)$$

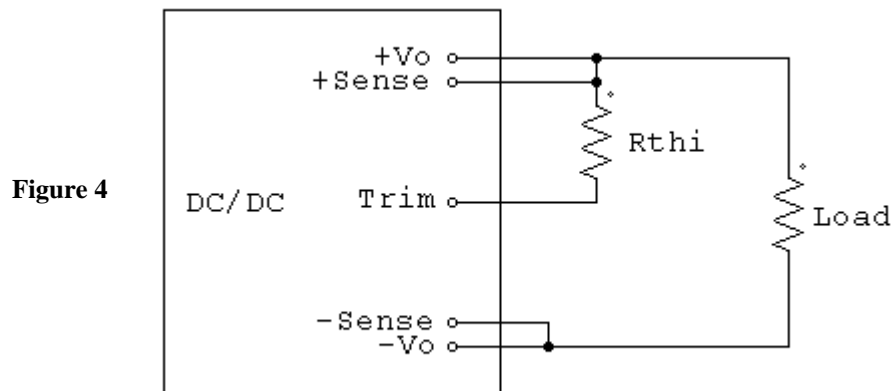

$$R_{thi} = \left[\frac{5.1 \cdot V_o (100 + \Delta\%)}{1.2225 \cdot \Delta\%} - \frac{510}{\Delta\%} - 10.2 \right]$$

Notes:

1. Maximum trim range is $\pm 10\%$. This includes remote sense drops if applicable.
2. Output current is limited to specified current when trimming down.
3. Output power is limited to specified power when trimming up.
4. Trim resistors should be placed close to the module.
5. If the trim function is not used, it is advised to leave the trim pin floating / not connected.

Graph 1: FA12S15-300 Efficiency vs. Output Current

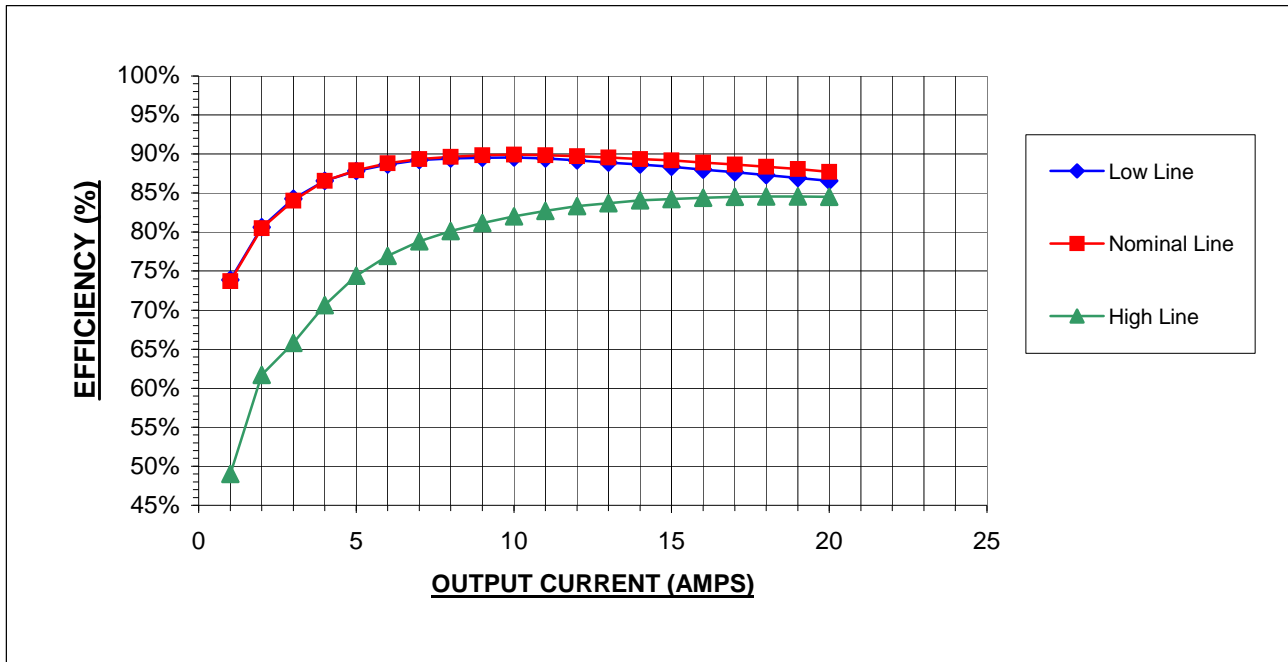

Graph 2: FA12S15-300 Max Ambient vs. Output Power

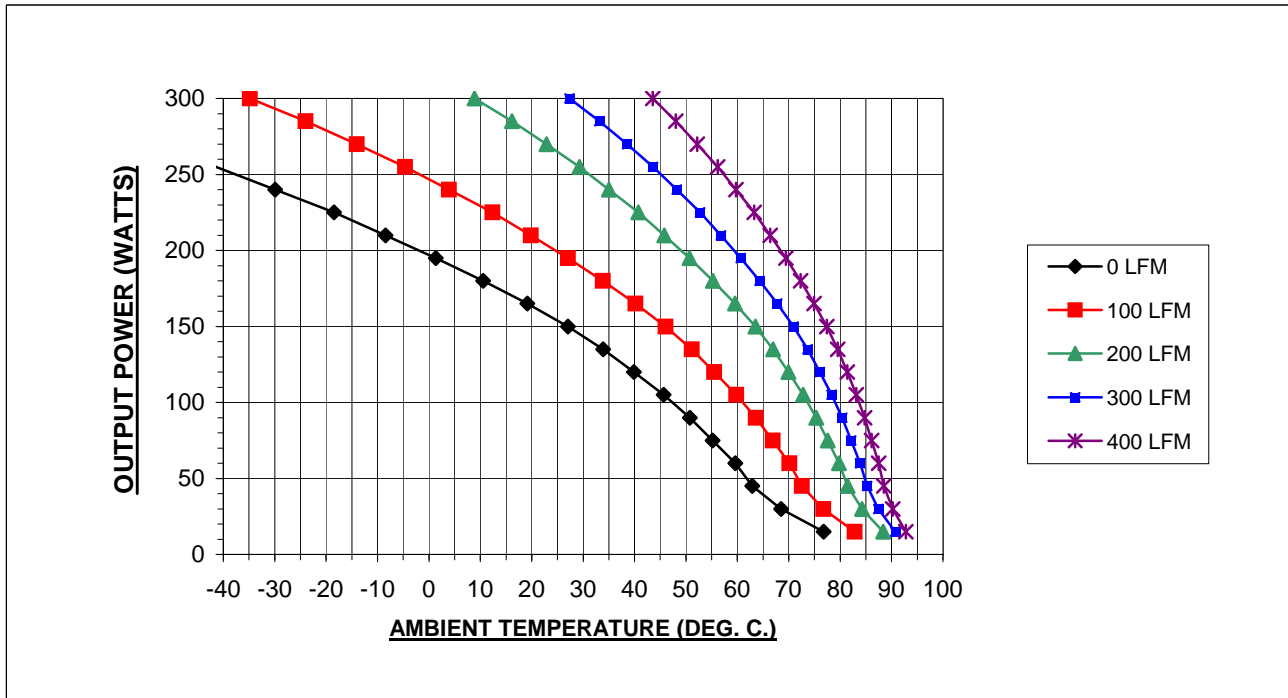

Note: When trimming the output high, I_o vs. Ambient is derated by power. i.e.: from Graph 2, find the maximum current at the desired ambient and airflow, and multiply this current by the nominal voltage (15V) to get the maximum power. Divide this power by the desired trimmed high voltage to get the maximum current at that ambient. When trimming low, the maximum current stays the same as shown in graph 2.

Graph 3: Input Current vs. Input Voltage

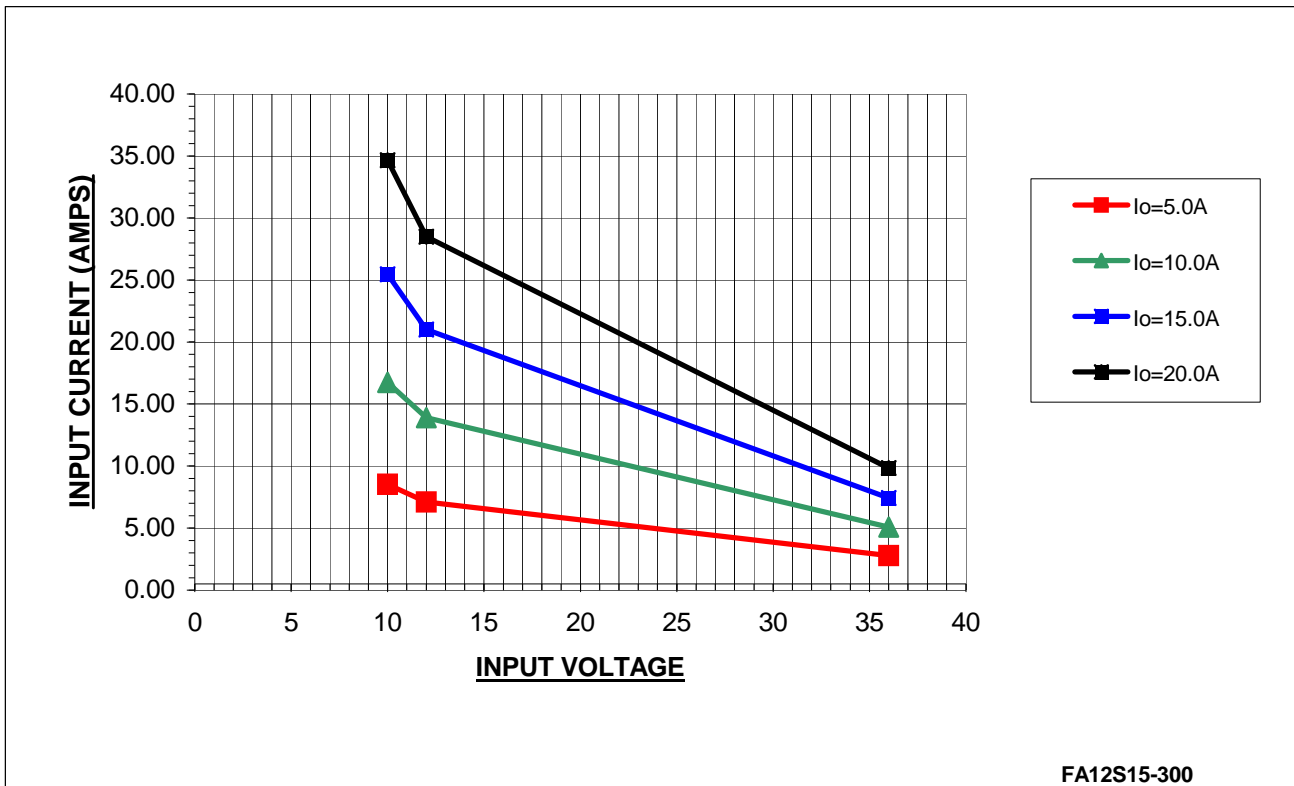

Graph 4: Power Dissipation vs. Input Voltage

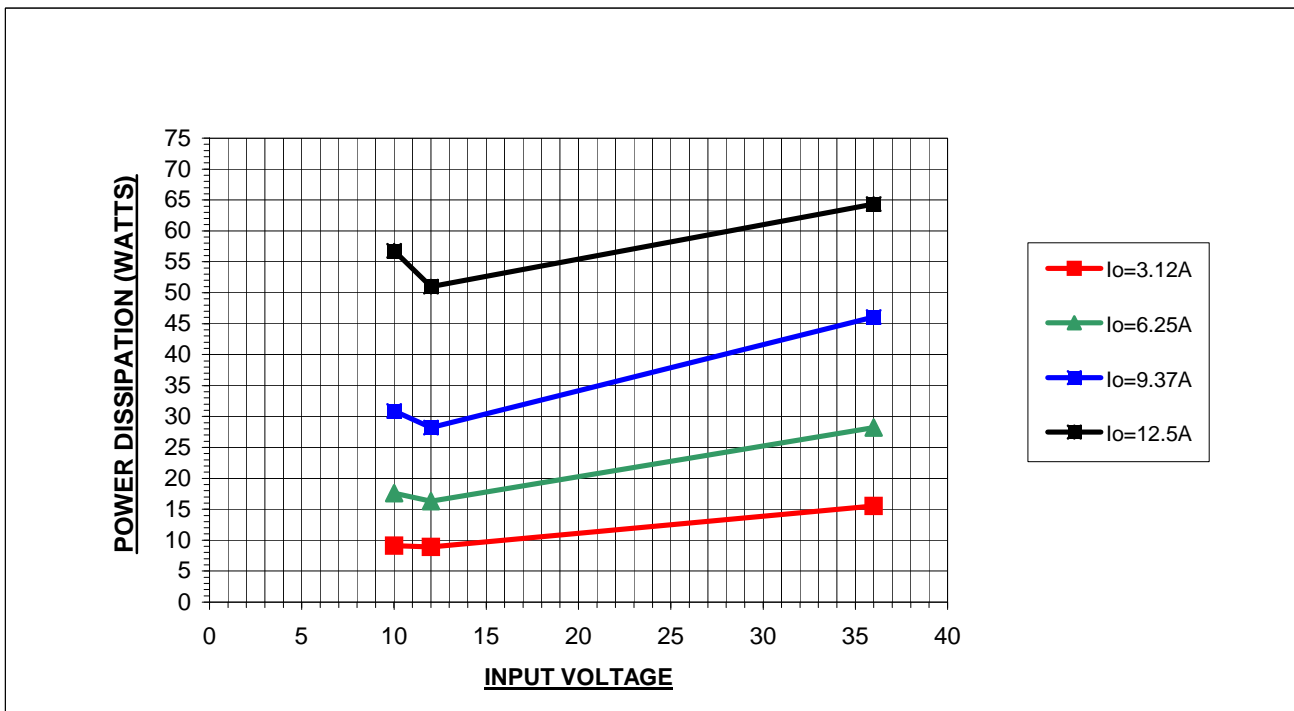

Graph 5: Power Dissipation vs. Input Voltage

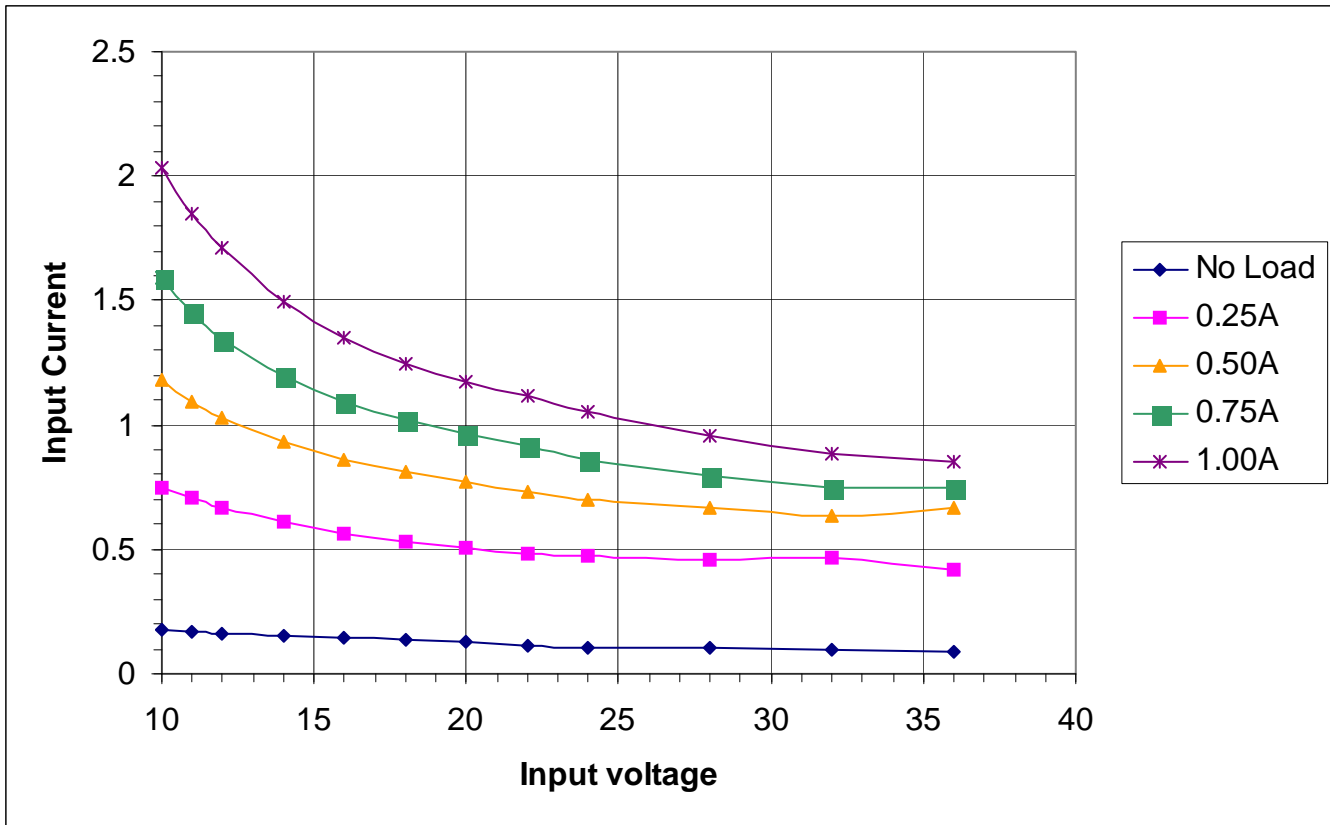

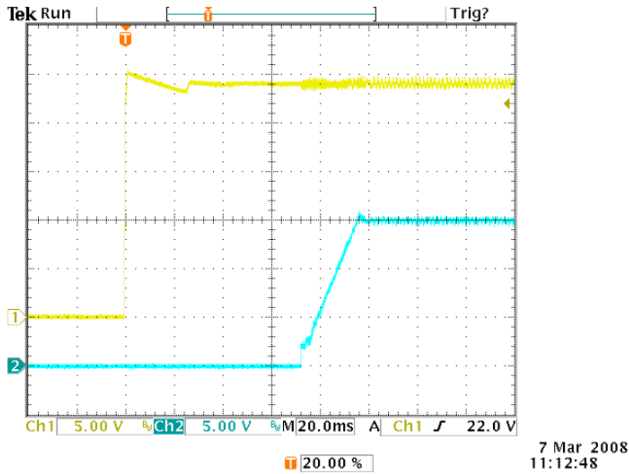

TDS 3012 - 11:15:09 AM 3/7/2008

Photo 1: Full load (resistive) startup.
Ch.1 = Vin (5V/div), CH.2 = Vout (5V/div).

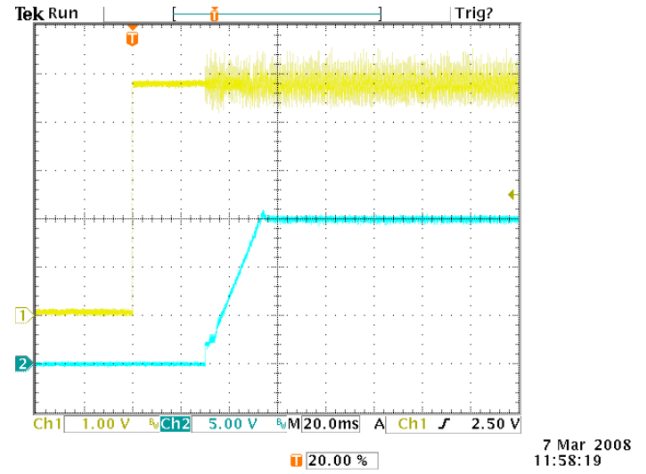

TDS 3012 - 12:00:40 PM 3/7/2008

Photo 2: Full load (resistive) startup, via logic enable.
Ch. 1 = L/E (1V /div), Ch.2 = Vout (5V/div).

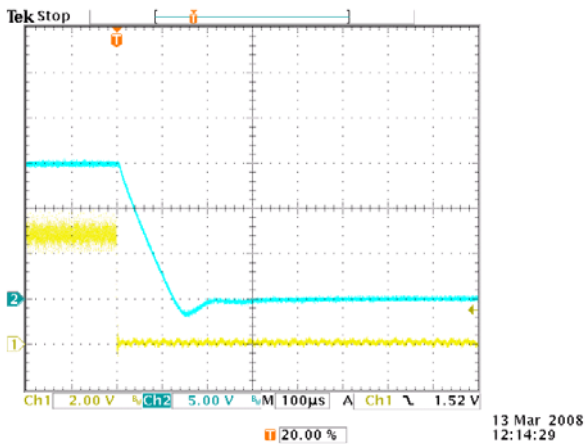

TDS 3012 - 1:16:52 PM 3/13/2008

Photo 3: Full load turn-off, via logic enable.
Ch.1 = L/E (2V/div), Ch.2 = Vout (5V/div).

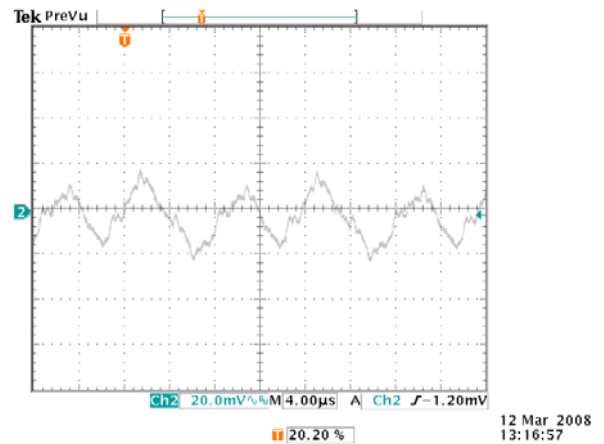

TDS 3012 - 2:19:20 PM 3/12/2008

Photo 4: Output ripple, 10Vin, full load.
20mV / div.

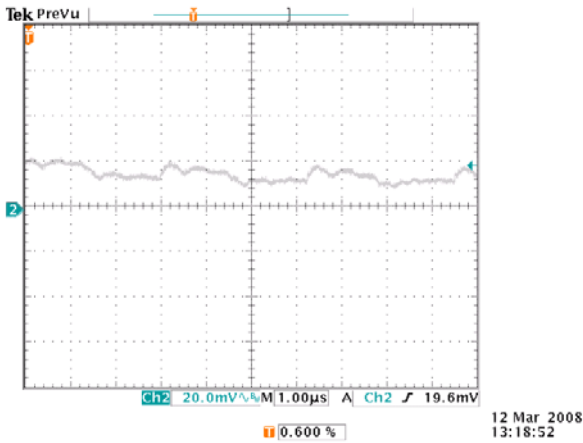

TDS 3012 - 2:21:15 PM 3/12/2008

Photo 5. Output ripple, 12Vin, full load.
20mV / div.

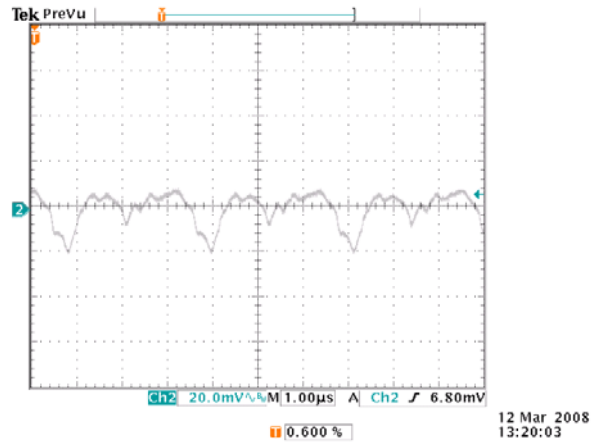

TDS 3012 - 2:22:25 PM 3/12/2008

Photo 6: . Output ripple, 36Vin, full load.
20mV / div.

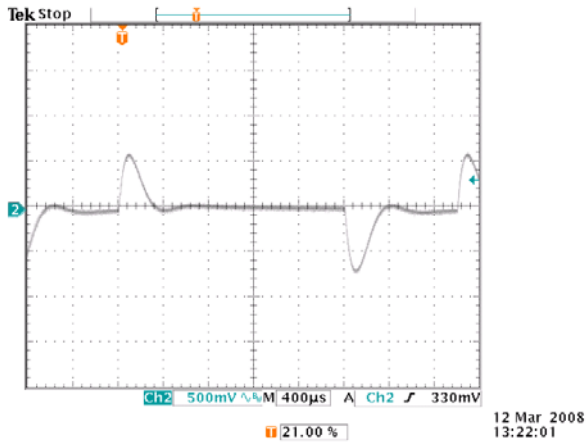

TDS 3012 - 2:24:22 PM 3/12/2008

Photo 7: Transient Response 50% to 100%
Vin=24V, Iout =10A to 20A @ 0.5V/ Div
Cout=0.1uF Ceramic + 10uF Tantalum

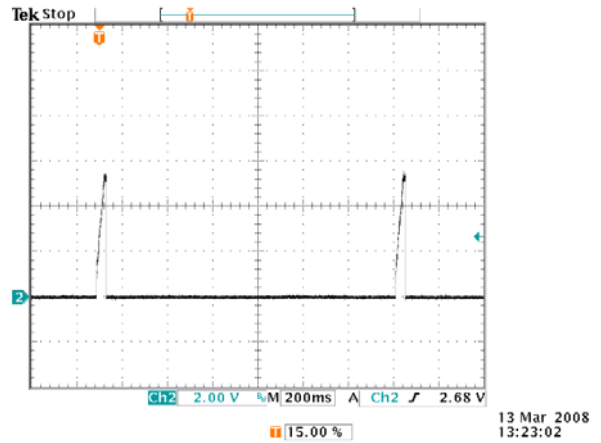

TDS 3012 - 2:25:26 PM 3/13/2008

Photo 8: Overload output current, 0.16 Ohm impedance.
24Vin, 12.5A / div.

TEST SETUP:

The FA12S15-300 specifications are tested with the following configurations:

Regulation and Efficiency Setup

To ensure that accurate measurement are taken, the voltage measurements are taken directly at the terminals of the module. This minimizes errors due to contact and trace lengths between the load and the output of the supply. The following diagram is of the test setup.

Figure 5: Regulation and Efficiency Probe Setup

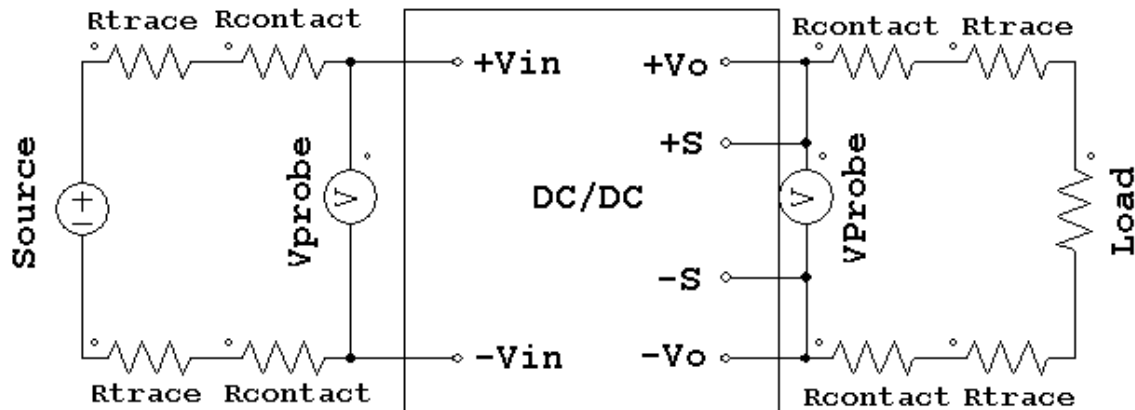

Output Ripple Voltage Setup

The module is tested with a $0.1\mu F$ ceramic capacitor in parallel with a $10\mu F$ tantalum capacitor across the output terminals. Unless otherwise specified, bandwidth is limited to 20MHz.

Figure 6: Ripple Voltage Probe Setup

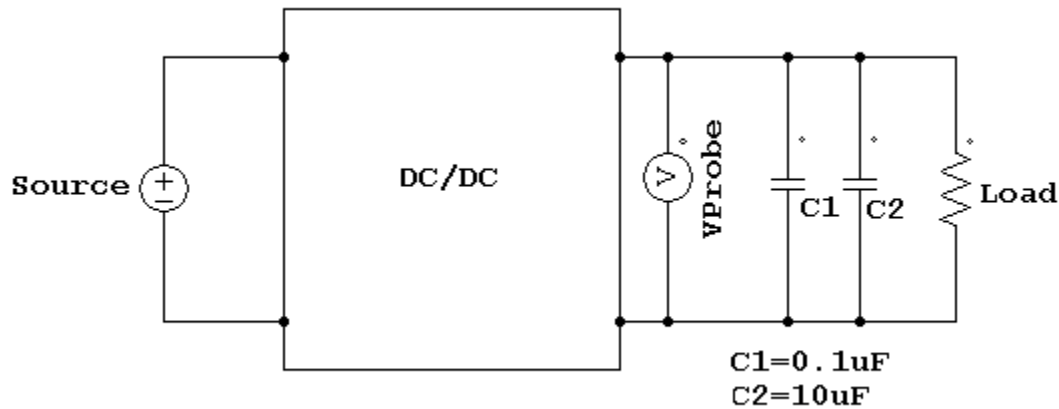

Input Reflected Ripple Current and Input Ripple Voltage Setup

The module is tested for input reflected ripple current (Irrc). The input ripple voltage is also measured at the pins with and without an additional 33 μ F electrolytic capacitor. To reduce either the input ripple current or voltage additional capacitors and/or an inductor may be added to the input of the converter.

Figure 7: Ripple Current Setup

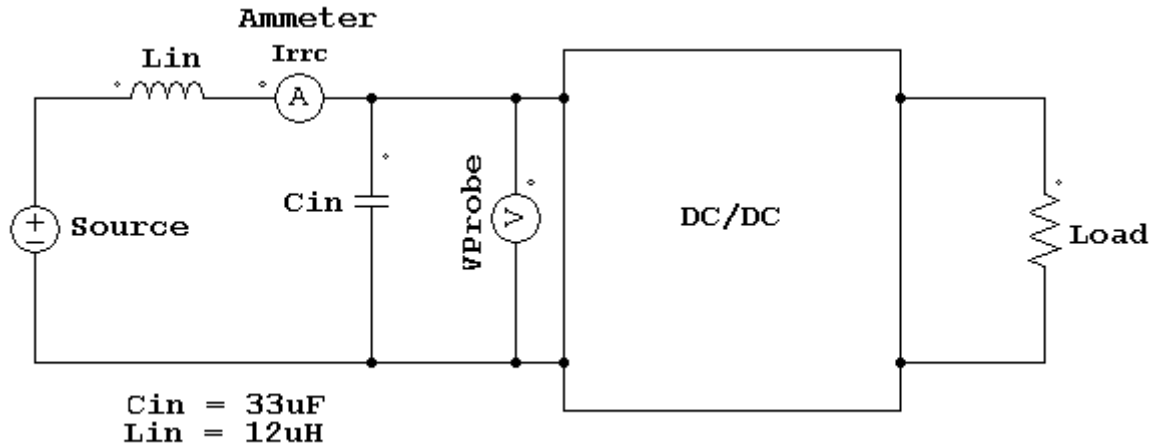

Converter Thermal Consideration

The converter is designed to operate without convective cooling if the de-rating curves are followed. The converter can operate at higher temperatures and higher output currents if airflow and/or a heatsink are applied. Airflow should be aligned lengthwise to the converter's heatsink fins for optimum heat transfer. See Graph 2 for de-rating curves or contact factory for additional thermal information.

Figure 8: Airflow Orientation

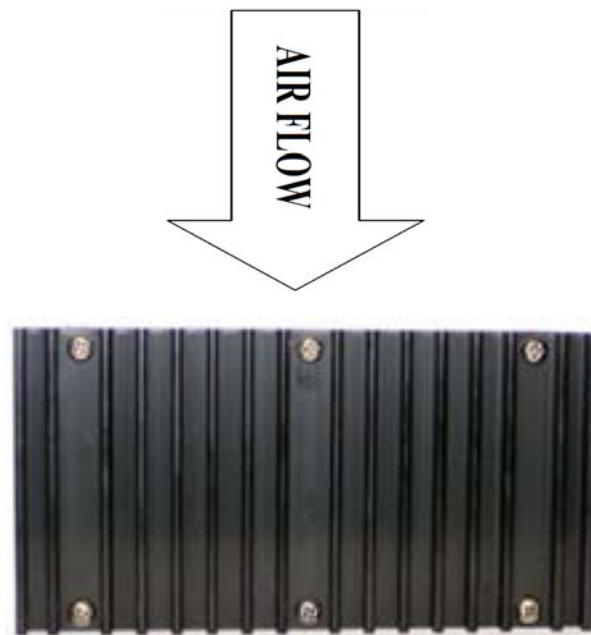

Paralleling Converters

The FA series converters may be paralleled both for redundancy and for higher output current. However, in order to do this, a high-current, low V_f , Schottky diode must be placed at the +Vo pin of each supply as shown in Figure 9. To improve sharing, tie the two TRIM pins together. The converters may be trimmed by adding a resistor value from each TRIM pin to $\pm RS$ pin, or alternatively, a single resistor of half the value from the common TRIM pins to the common $\pm RS$ pins.

Figure 9: Paralleling Converters

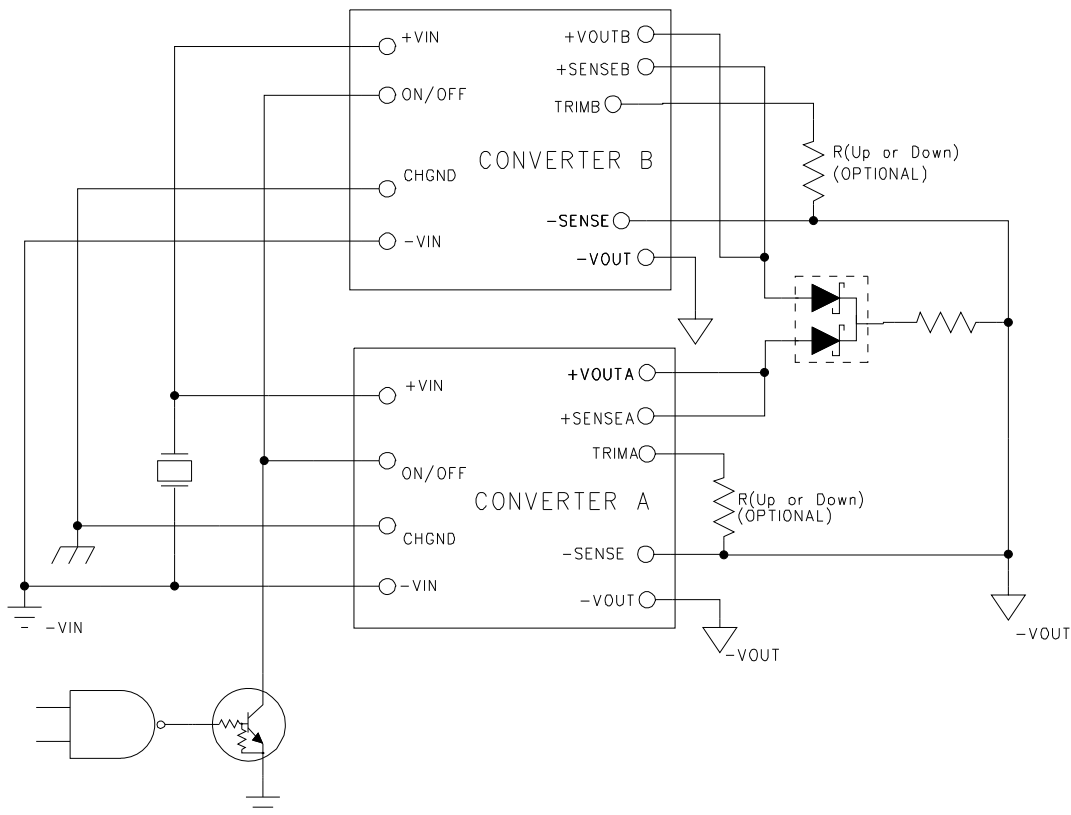

Ordering Information:

Part Number Example:

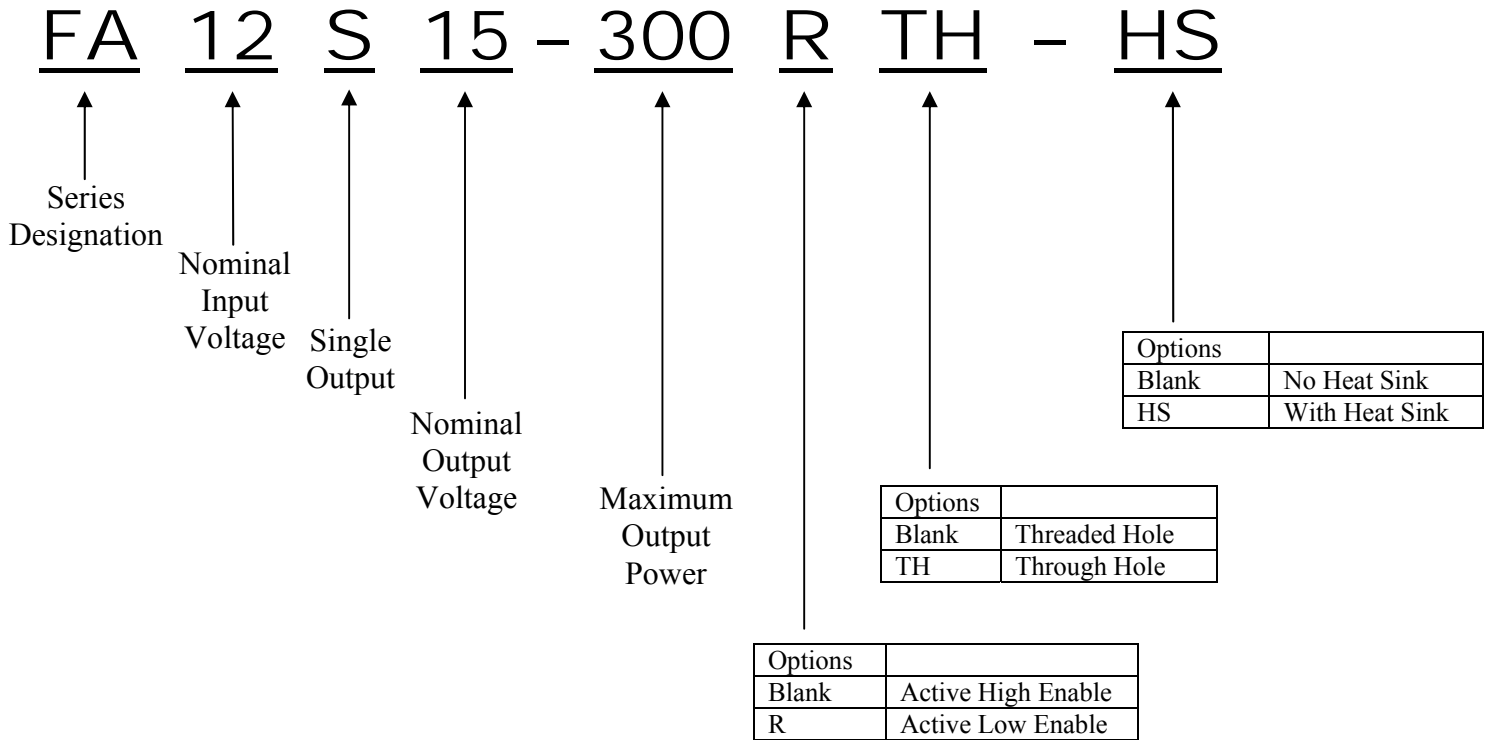

Company Information:

Wall Industries, Inc. has created custom and modified units for over 50 years. Our in-house research and development engineers will provide a solution that exceeds your performance requirements on time and on budget. Our ISO9001-2008 certification is just one example of our commitment to producing a high quality, well-documented product for our customers.

Our past projects demonstrate our commitment to you, our customer. Wall Industries, Inc. has a reputation for working closely with its customers to ensure each solution meets or exceeds form, fit and function requirements. We will continue to provide ongoing support for your project above and beyond the design and production phases. Give us a call today to discuss your future projects.

Contact **Wall Industries** for further information:

Phone: ☎ (603)778-2300
Toll Free: ☎ (888)587-9255
Fax: ☎ (603)778-9797
E-mail: sales@wallindustries.com
Web: www.wallindustries.com
Address: 5 Watson Brook Rd.
 Exeter, NH 03833