

Wall Industries, Inc.

JFW48S3.3-4000

DC/DC Converter
18-75 VDC Input
3.3 VDC Output at 4A

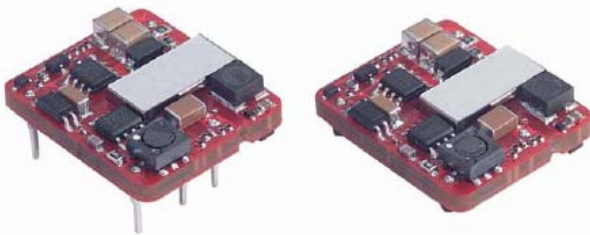

Features:

- 15 Watts Output Power
- 4:1 Ultra Wide Input Voltage of 9-36 and 18-75VDC
- Industry Standard Pin-Out
- High Efficiency Up to 87%
- Low Profile: 1.10 x 0.94 x 0.335 inches
- Fixed Switching Frequency
- RoHS Directive Compliant
- No Minimum Load
- Input to Output Isolation: 2250VDC, min
- Input Under-Voltage Protection
- Output Over-Voltage Protection
- Over-Current Protection, Auto-Recovery
- Output Short Circuit Protection
- Remote ON/OFF Control
- Adjustable Output Voltage
- Surface Mount or Through Hole
- Cost Efficient Open Frame Design

Applications:

- Distributed Power Architectures
- Communication Equipment
- Computer Equipment
- Test Equipment

Options:

- Positive Remote ON/OFF
- **On/Off Control Function**
- **Trim Function**
- Surface Mount

Description:

JFW Series single output DC/DC converters provide up to 15 watts of output power in an industry standard package and footprint. These units are specifically designed to meet the power needs of low profile. All models feature with 4:1 ultra wide input voltage of 9-36VDC and 18-75VDC, comprehensively protected against over-current, over-voltage and input under-voltage protection conditions, and trimmable output voltage.



Wall Industries, Inc.

TECHNICAL DATASHEET

JFW48S3.3-4000

Technical Specifications		Model No. JFW48S3.3-4000			
All specifications are based on 25 °C, Nominal Input Voltage and Maximum Output Current unless otherwise noted. We reserve the right to change specifications based on technological advances.					
SPECIFICATION	Related condition	Min	Nom	Max	Unit
Switching Frequency	Test at nominal Vin and full load		350		kHz
INPUT (Vin)					
Operating Voltage Range		18	48	75	Vdc
Input Voltage (Continuous)				75	Vdc
Input Voltage (Transient 100ms)				100	Vdc
UVLO Turn-on Threshold				18	Vdc
UVLO Turn-off Threshold			16		Vdc
Input Standby Current	Nominal Vin and No Load		40		mA
Input Voltage Variation	Complies with EST300 132 part 4.4			5	V/ms
Input Current	Nominal Vin and Full Load			340	mA
Reflected Ripple Current	5 to 20MHz, 12µH source impedance (See the Test Setup section - pg 9)		30		mA _{pk-pk}
Remote Off Input Current			2.5		mA
Input Current of Remote Control Pin		-0.5		1.0	mA
EFFICIENCY	Test at nominal Vin and full load (See the Test Setup section – pg 9)		85		%
OUTPUT (Vo)					
Operating Output Range	Nominal Vin and Full Load	3.267 -1%	3.3	3.333 +1%	Vdc
Voltage Adjustment	See the External Trim Adjustment section (pg 6)	2.97 -10%	3.3	3.63 +10%	Vdc
Load Regulation	0% to 100% Full Load	-0.2		+0.2	%
Line Regulation	LL to HL at Full Load	-0.2		+0.2	%
Output Ripple & Noise	1µF Ceramic & 10µF Tantalum at 20MHz bandwidth (See the Test Setup section - pg 9)		100		mV _{pk-pk}
Output Current		0		4.0	A
Output Voltage Overshoot	LL to HL at Full Load			3	% Vout
Over Voltage Protection	Voltage clamped	3.7		5.4	Vdc
Over Current Protection			150		% FL
Short Circuit Protection			Hiccup, automatic recovery		
DYNAMIC LOAD RESPONSE					
Peak Deviation	Test at nominal Vin Load step change from 75 to 100% or 100 to 75 % of FL		300		mV
Setting Time (Vout < 10% peak deviation)			250		µs
REMOTE ON/OFF					
The ON/OFF pin voltage is referenced to -Vin (See the Remote ON/OFF Control section - pg 5)					
Negative Logic	DC-DC ON (Short)	0		1.2	Vdc
	DC-DC OFF (Open)	3		12	Vdc
Positive Logic	DC-DC ON (Open)	3		12	Vdc
	DC-DC OFF (Short)	0		1.2	Vdc
START UP TIME					
Power Up	Test at nominal Vin and constant resistive load		30		ms
Remote ON/OFF			30		ms
ISOLATION					
Isolation Voltage (Input-Output)		2250			Vdc
Isolation Resistance		10			GΩ
Isolation Capacitance				1000	pF
ENVIRONMENTAL					
Operating Ambient Temperature (w/ derating)		-40		+85	°C
Storage Temperature		-55		+125	°C
Temperature Coefficient		-0.02		+0.02	% / °C
MTBF					
See the MTBF and Reliability section (pg 15)					
Bellcore TR-NWT-000332, Tc=40°C			1,322,000		hours
MIL-STD-217F			514,700		hours
MECHANICAL					
See Figure 1					
Weight			10.5		grams
Dimensions			1.10 x 0.94 x 0.335		inches

Figure 1: Mechanical Dimensions

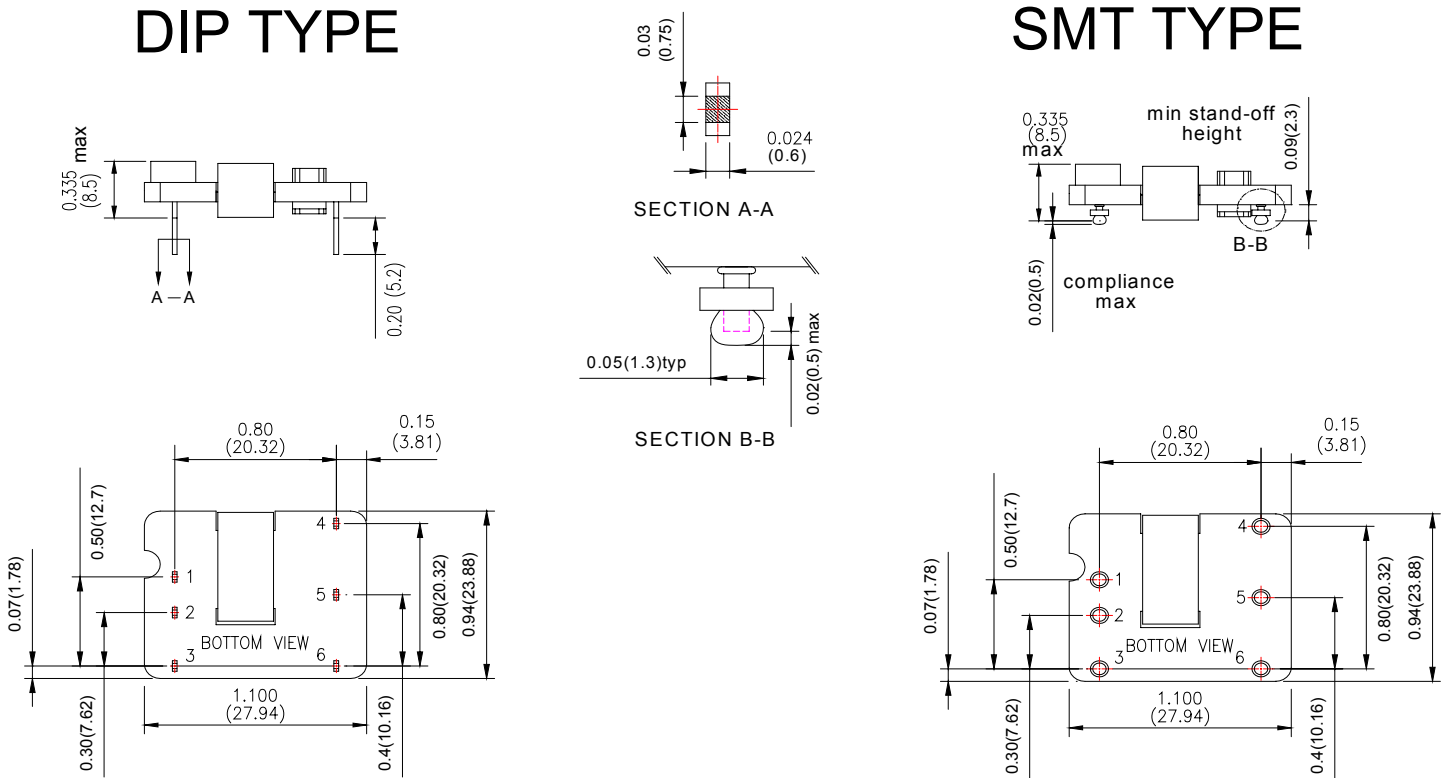

Table 1

PIN CONNECTION	
PIN	JFW48S3.3-4000
1	+ INPUT
2	- INPUT
3	ON/OFF
4	+VOUT
5	TRIM
6	-VOUT

Figure 2

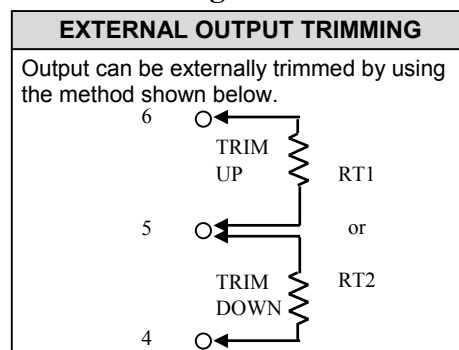

Table 2

PRODUCT STANDARD TABLE	
Option	Suffix
Negative Remote ON/OFF with DIP	R
Negative Remote ON/OFF with SMT	SR
Positive Remote ON/OFF with DIP	Blank
Positive remote ON/OFF with SMT	S
DIP type without ON/OFF pin	D
SMT type without ON/OFF pin	SD
DIP type without ON/OFF & TRIM pin	G
SMT type without ON/OFF & TRIM pin	SG
DIP type without TRIM pin	F
SMT type without TRIM pin	SF

NOTES:

- All dimensions in inches (mm)
- Tolerance: $x.xx \pm 0.02$ ($x.x \pm 0.5$)
 $x.xxx \pm 0.010$ ($x.xx \pm 0.25$)
- Pin pitch tolerance: ± 0.014 (0.35)

DESIGN CONSIDERATIONS:**Output Over Current Protection**

When excessive output currents occur in the system, circuit protection is required on all power supplies. Normally, overload current is maintained at approximately 150% of rated current for the JFW Series.

Hiccup-mode is a method of operation in a power supply whose purpose is to protect the power supply from being damaged during an over-current fault condition. It also enables the power supply to restart when the fault is removed.

One of the problems resulting from over current is that excessive heat may be generated in power devices; especially MOSFET and Schottky diodes and the temperature of those devices may exceed their specified limits. A protection mechanism has to be used to prevent those power devices from being damaged.

Output Over Voltage Protection

The output over-voltage protection consists of a Zener diode that monitors the output voltage on the feedback loop. If the voltage on the output terminals exceeds the over-voltage protection threshold, then the Zener diode will send a current signal to the control IC to limiting the output voltage.

Input Source Impedance

The power module should be connected to a low impedance input source. Highly inductive source impedance can affect the stability of the power module. Input external C-L-C filter is recommended to minimize input reflected ripple current. The inductor is simulated source impedance of 12 μ H and capacitor is Nippon chemi-con KZE series 220 μ F/100V&33 μ F/100V. The capacitor must as close as possible to the input terminals of the power module for lower impedance.

Short Circuit Protection

Continuous, hiccup and auto-recovery mode.

During short circuit, converter still shut down. The average current during this condition will be very low and the device can be safety in this condition.

Thermal Consideration

The power module operates in a variety of thermal environments. However, sufficient cooling should be provided to help ensure reliable operation of the unit. Heat is removed by conduction, convection, and radiation to the surrounding environment. Proper cooling can be verified by measuring the point as the figure below. The temperature at this location should not exceed 120°C. When operating, adequate cooling must be provided to maintain the test point temperature at or below 120°C. Although the maximum point temperature of the power modules is 120°C, you can limit this temperature to a lower value for extremely high reliability.

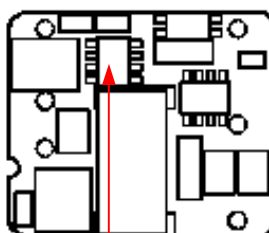
Figure 3**TOP VIEW**

Temperature Measure Point

Remote ON/OFF Control

The Remote ON/OFF Pin is controlled DC/DC power module to turn on and off; the user must use a switch to control the logic voltage high or low level of the pin referenced to $V_i (-)$. The switch can be open collector transistor, FET and Photo-Couple. The switch must be capable of sinking up to 1mA at low-level logic Voltage. High-level logic of the ON/OFF signal maximum voltage is allowable leakage current of the switch at 15V is 50uA.

Figure 4

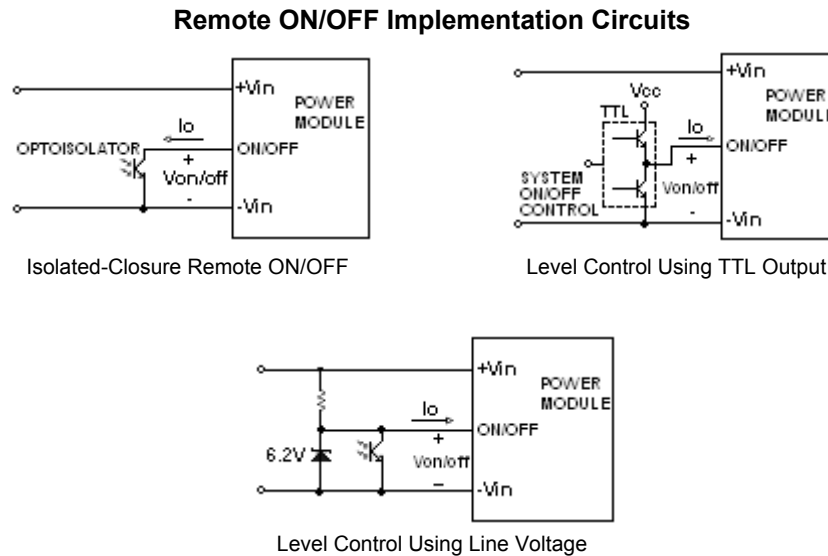

There are two remote control options available, positive logic and negative logic.

- a. The Positive logic structure turned on the DC/DC module when the ON/OFF pin is at high-level logic and low-level logic is turned off it.

Figure 5

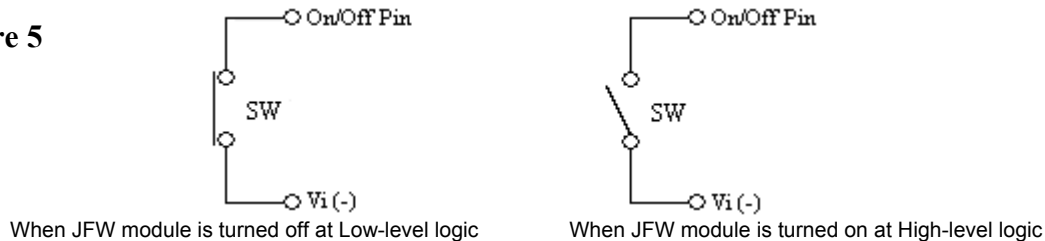

- b. The Negative logic structure turned on the DC/DC module when the ON/OFF pin is at low-level logic and turned off when at high-level logic.

Figure 6

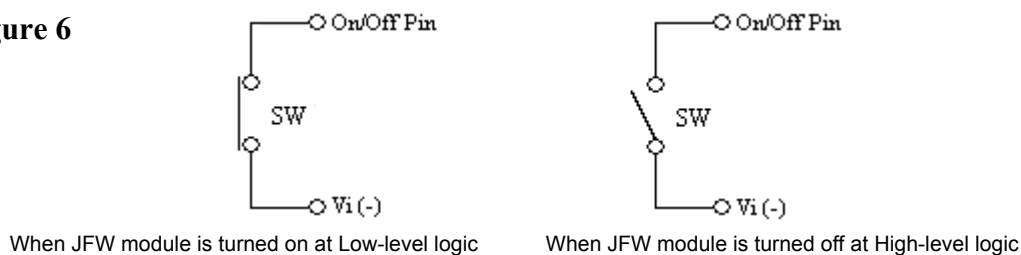

External Trim Adjustment

Output voltage set point adjustment allows the user to increase or decrease the output voltage set point of a module. This is accomplished by connecting an external resistor between the TRIM pin and either the +Vout or -Vout pins. With an external resistor between the TRIM and +Vout pin, the output voltage set point decreases. With an external resistor between the TRIM and -Vout pin, the output voltage set point increases.

$$R_{up} = \frac{5110 * 2.5}{V_o^+ - 2.5 - 0.8} - 2050 \quad (\text{in } \Omega)$$

V_o^+ is the desired up output voltage

$$R_{down} = \frac{(V_o^- - 2.5) * 5110}{V_{out} - (V_o^-)} - 2050 \quad (\text{in } \Omega)$$

V_o^- is the desired down output voltage

Table 3 Trim Resistor Values

Trim	V_o^+	R_{up}	V_o^-	R_{down}
1%	3.333V	385.071 k Ω	3.267V	116.719 k Ω
2%	3.366V	191.511 k Ω	3.234V	54.779 k Ω
3%	3.399V	126.99 k Ω	3.201V	34.133 k Ω
4%	3.432V	94.73 k Ω	3.168V	23.810 k Ω
5%	3.465V	75.374 k Ω	3.135V	17.616 k Ω
6%	3.498V	62.47 k Ω	3.102V	13.486 k Ω
7%	3.531V	53.253 k Ω	3.069V	10.537 k Ω
8%	3.564V	46.34 k Ω	3.036V	8.325 k Ω
9%	3.597V	40.963 k Ω	3.003V	6.604 k Ω
10%	3.63V	36.662 k Ω	2.97V	5.228 k Ω

Figure 7

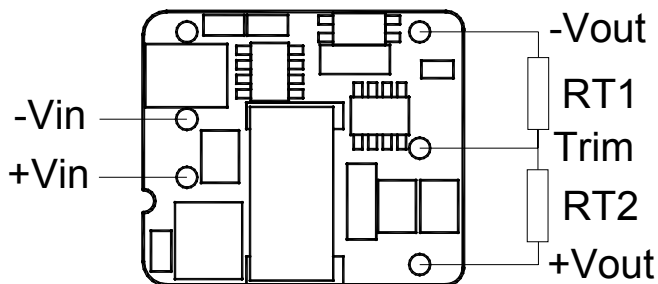

Graph 1: Efficiency vs. Output Current

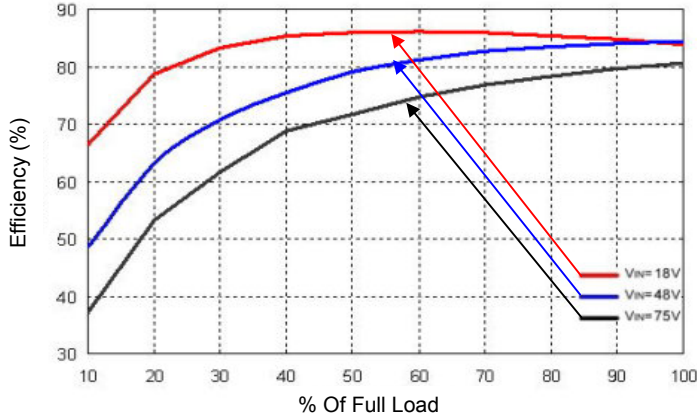

Graph 2: Efficiency vs. Input Voltage (Full Load)

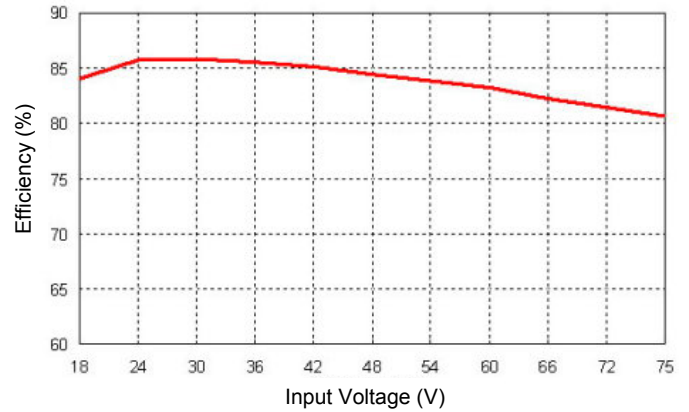

Graph 3: Output Power vs. Ambient Temperature & Airflow (Nominal Vin)

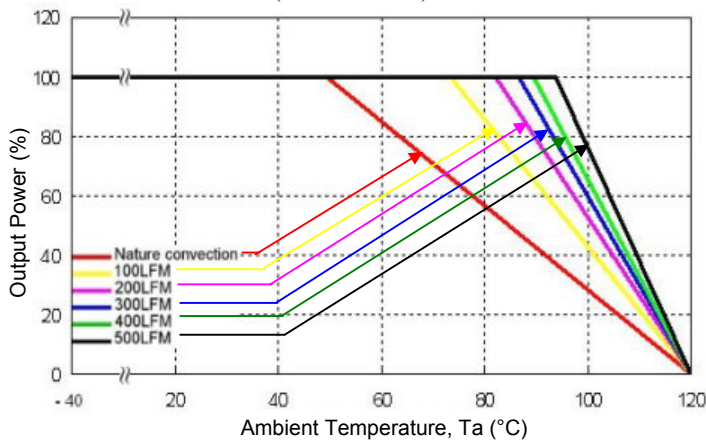

Graph 4: Power Dissipation Vs. Output Current

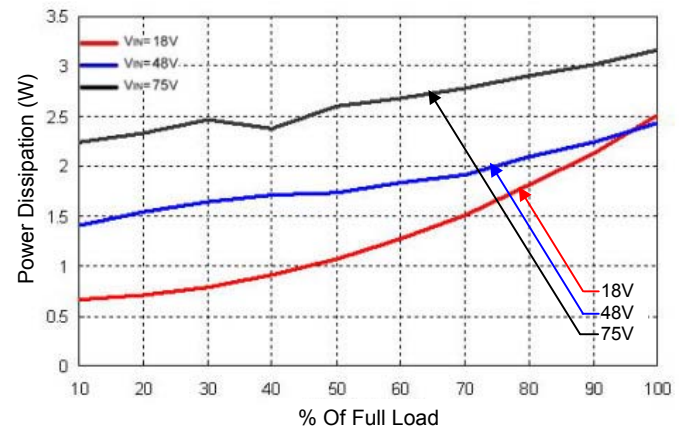

Graph 5: Conducted Emission of EN55022 Class A (Nominal Vin and Full Load)

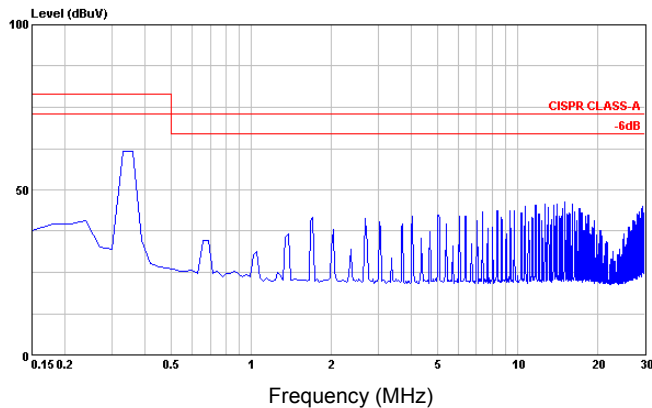

Graph 6: Conducted Emission of EN55022 Class B (Nominal Vin and Full Load)

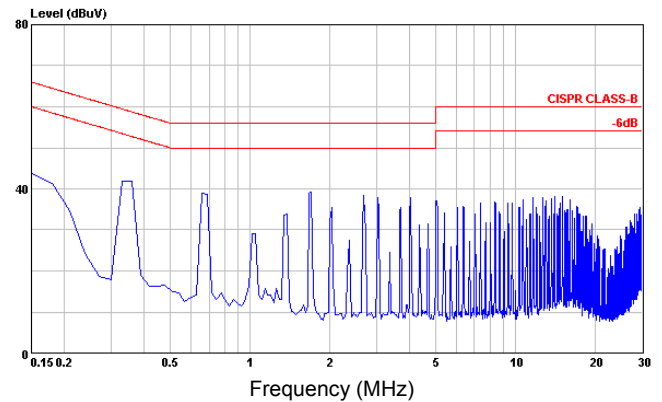

Graph 7: Typical Input Start-Up and Output Rise Characteristic (Nominal Vin and Full Load)

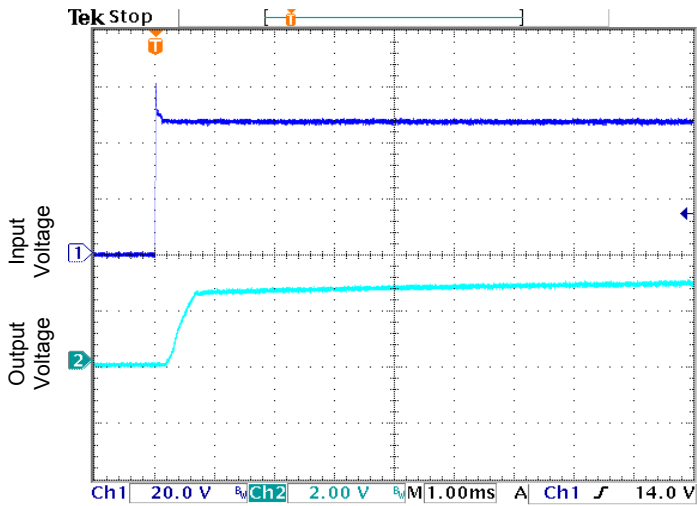

Graph 8: Typical Output Ripple and Noise (Nominal Vin and Full Load)

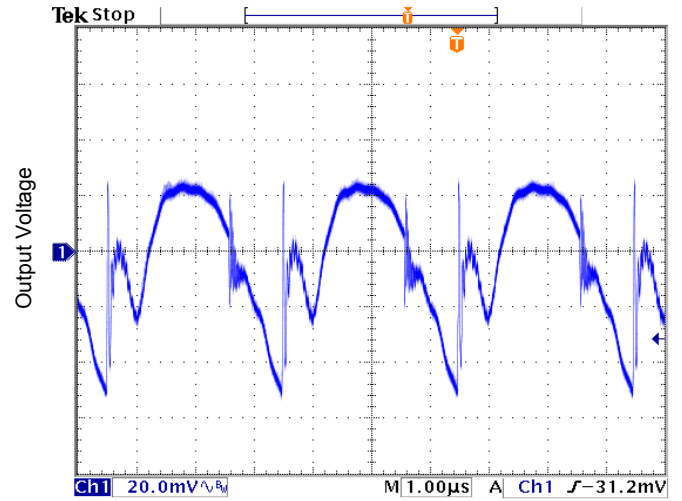

Graph 9: Using ON/OFF Voltage Start-Up and Vo Rise Characteristic (Nominal Vin and Full Load)

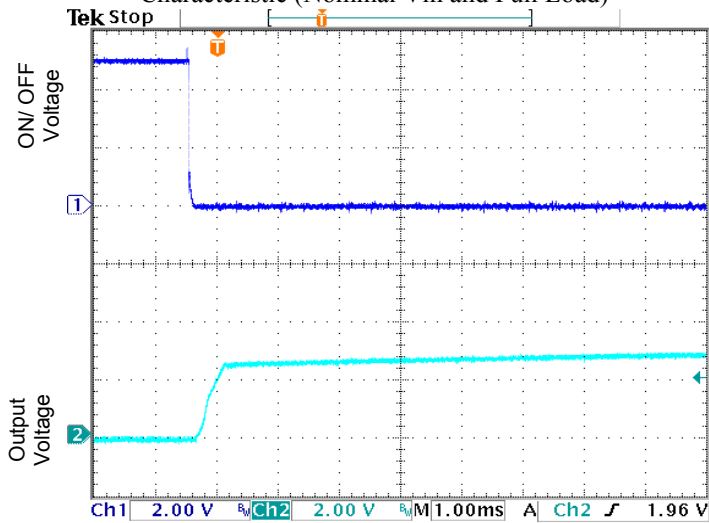

Graph 10: Transient Response to Dynamic Load Change from 100% to 75% to 100% of Full Load at Nominal Vin

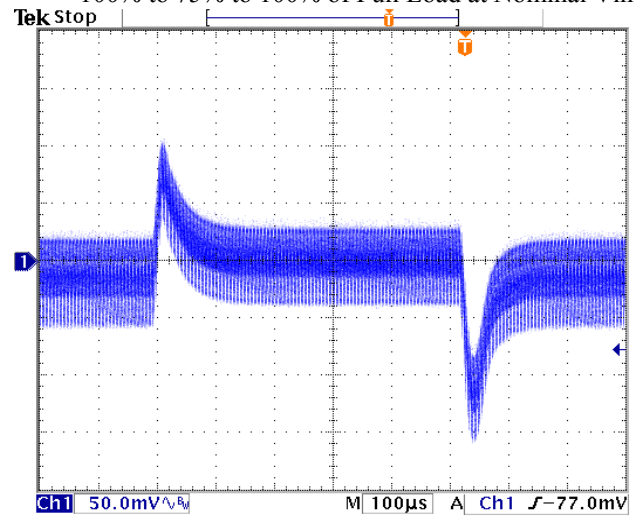

TEST SETUP:

The JFW48S3.3-4000 specifications are tested with the following configurations:

Input Reflected-Ripple Current Measurement Test Setup

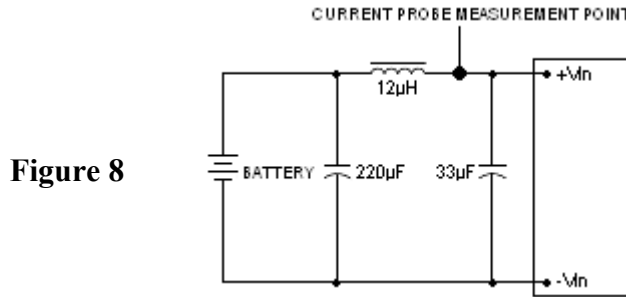

Component	Value	Voltage	Reference
L	12µH	----	----
C	220µF	100V	Aluminum Electrolytic Capacitor
C	33µF	100V	Aluminum Electrolytic Capacitor

Peak-to-Peak Output Ripple & Noise Measurement Setup

Figure 9

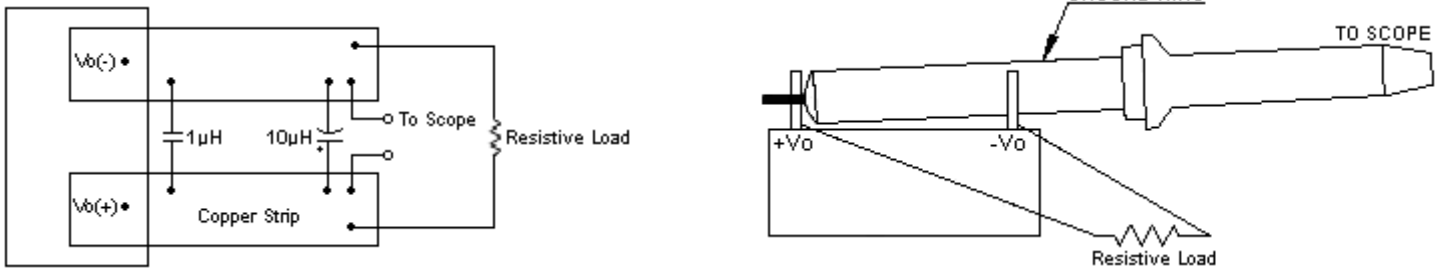

Output Voltage and Efficiency Measurement Setup

Figure 10

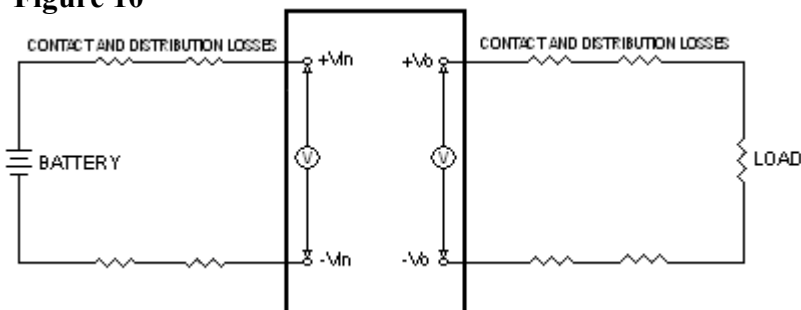

$$Efficiency = \left(\frac{V_{out} \times I_{out}}{V_{in} \times I_{in}} \right) \times 100\%$$

NOTE: All measurements are taken at the module terminals

EMC Considerations

Suggested schematic for EN55022 conducted emission Class A limits

Figure 11

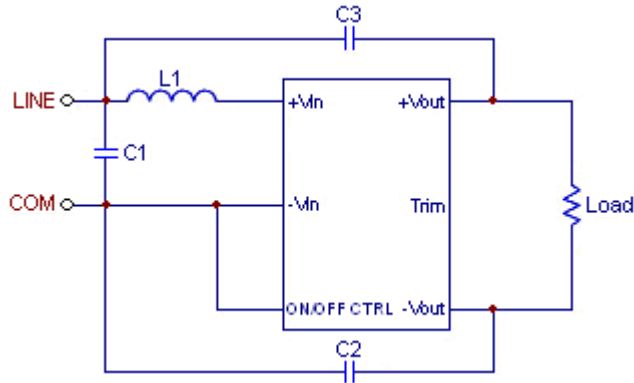

Recommended Layout with Input Filter

Figure 12

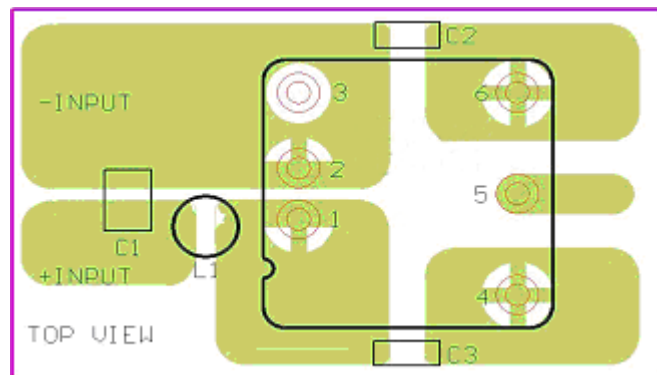

To meet conducted emissions EN55022 CLASS A needed the following components:

JFW24Sxx-xxxx

Component	Value	Voltage	Reference
L1	2.2uH	----	2.3A 0.025Ω 0504 SMD Inductor P/N: PMT-059
C1	2.2uF	50V	1812 MLCC
C2, C3	470pF	3KV	1808 MLCC

JFW48Sxx-xxxx

Component	Value	Voltage	Reference
L1	10uH	----	1.4A 0.1Ω 0504 SMD Inductor P/N: PMT-047
C1	2.2uF	100V	1812 MLCC
C2, C3	470pF	3KV	1808 MLCC

EMC Considerations (Continued)

Suggested schematic for EN55022 conducted emission Class B limits

Figure 13

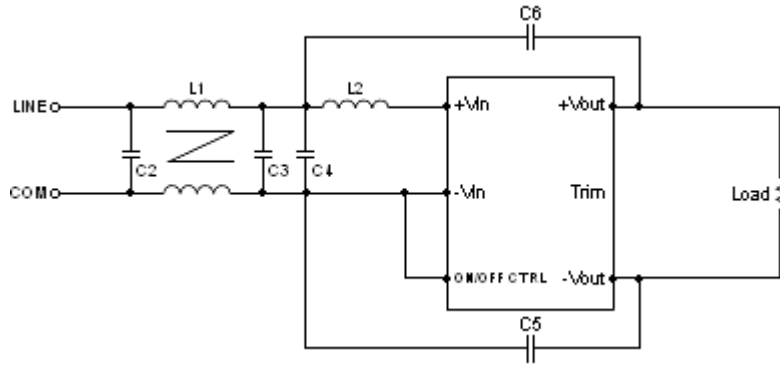

Recommended layout with input filter

Figure 14

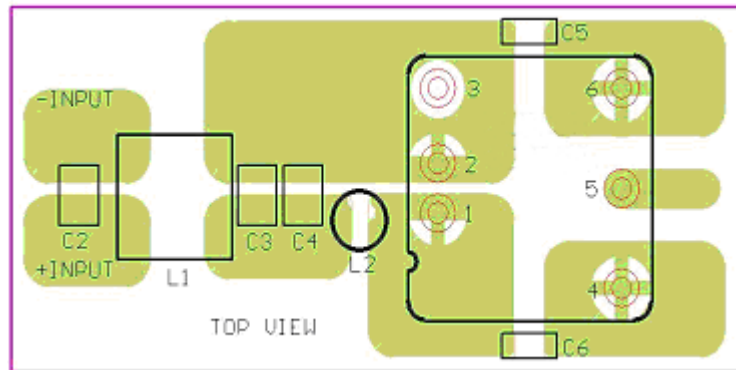

To meet conducted emissions EN55022 CLASS B needed the following components:

JFW24Sxx-xxxx

Component	Value	Voltage	Reference
C2, C3	2.2 μ F	50V	1812 MLCC
C4	----	----	----
C3, C4	1000pF	2KV	1808 MLCC
L1	550 μ H	----	Common Choke, P/N: PMT-058
L2	2.2 μ H	----	2.3A 0.025 Ω 0504 SMD Inductor P/N: PMT-059

JFW48Sxx-xxxx

Component	Value	Voltage	Reference
C2, C3	2.2 μ F	100V	1812 MLCC
C4	----	----	----
C3, C4	1000pF	2KV	1808 MLCC
L1	550 μ H	----	Common Choke, P/N: PMT-058
L2	10 μ H	----	1.4A 0.1 Ω 0504 SMD Inductor P/N: PMT-047

Recommended Pad Layout for DIP Type

ALL Dimensions in millimeters (inches)
Tolerances: xx.xx mm ± 0.25mm (xx.xxx in ± 0.010 in)

Figure 15

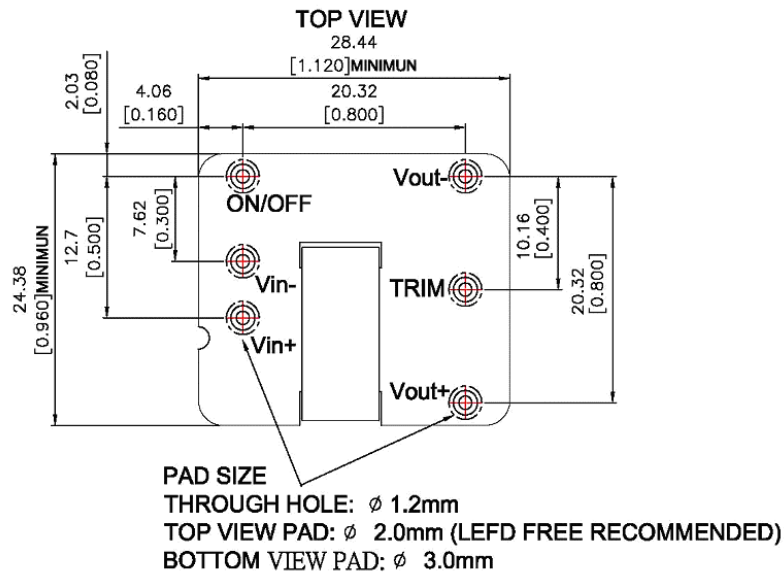

Recommended Pad Layout for SMT Type

ALL Dimensions in millimeters (inches)
Tolerances: xx.xx mm ± 0.25mm (xx.xxx in ± 0.010 in)

Figure 16

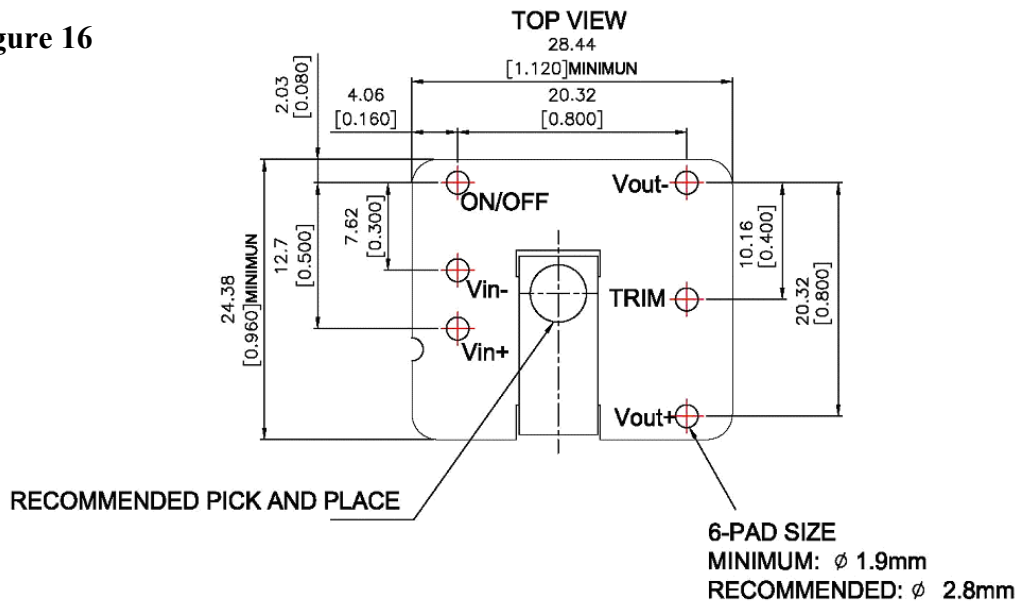

Soldering and Reflow Considerations:

Lead Free Wave Solder Profile for DIP Type

Figure 17

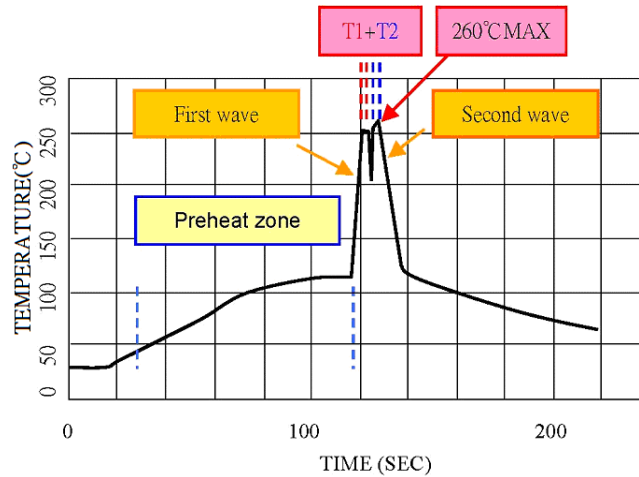

Zone	Reference Parameter
Preheat Zone	Rise temp. speed: 3°C/sec max. Preheat temp: 100~130°C
Actual Heating	Peak temp: 250~260°C Peak time (T1+T2 time): 4~6 sec

Lead free reflow profile for SMT type

Figure 18

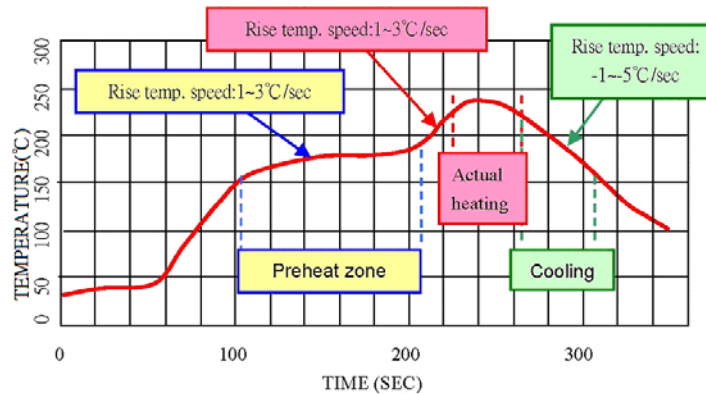

Zone	Reference Parameter
Preheat Zone	Rise temp. speed: 1~3°C/sec Preheat time: 60~90sec Preheat temp. 155~185°C
Actual Heating	Rise temp. speed: 1~3°C/sec Melting time: 20~40 sec Melting temp: 220°C Peak temp: 230~240°C Peak time: 10~20 sec
Cooling	Rise temp. speed: -1~-5°C/sec

Packaging Information:

DIP Type

Figure 19

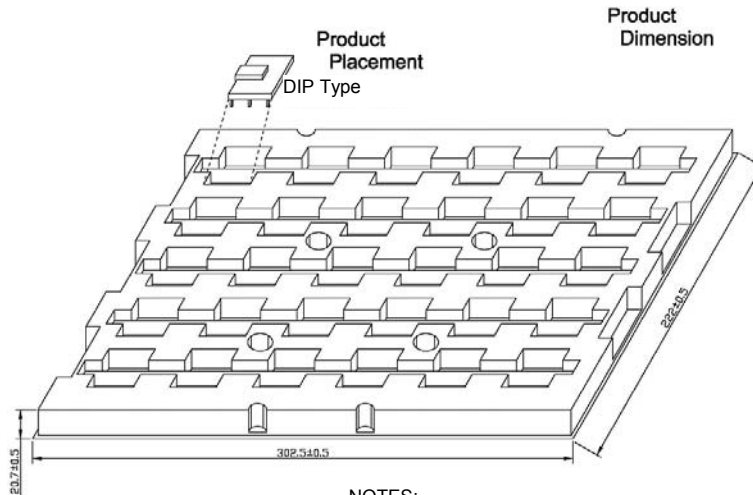

NOTES:
1. Material: PS (thick=1.2mm)

SMT Type

Figure 20

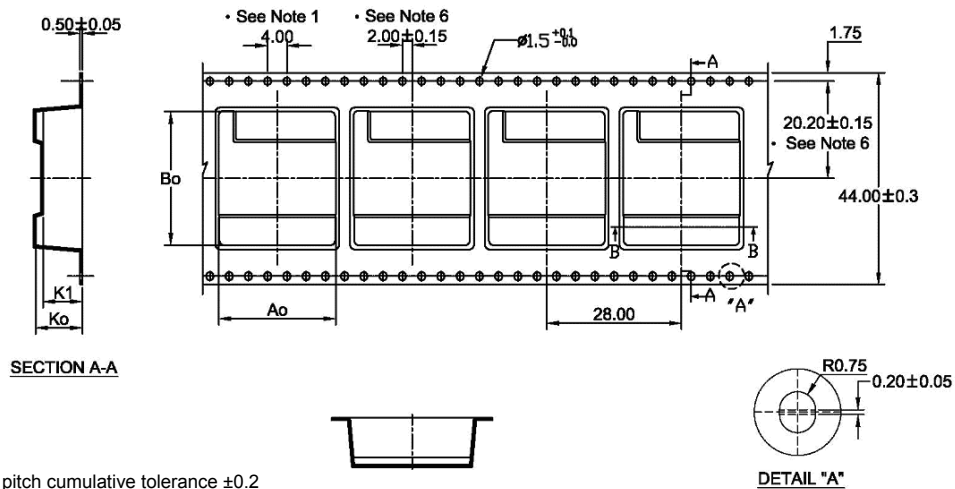

- NOTES:
1. 10 sprocket hole pitch cumulative tolerance ± 0.2
 2. Camber not to exceed 1mm in 100mm.
 3. Material: Black Advantek Polystyrene.
 4. A_o and B_o measured on a plane 0.3mm above the bottom of the pocket.
 5. K_o measured from a plane on the inside bottom of the pocket to the top surface of the carrier tape.
 6. Pocket position relative to sprocket hole measured as true position of pocket, not pocket hole.

$A_o=24.30\text{mm}$
 $B_o=27.80\text{mm}$
 $K_o= 9.70\text{mm}$
 $K1= 8.20\text{mm}$

Safety and Installation Instruction:**Fusing Consideration**

Caution: This power module is not internally fused. An input line fuse must always be used.

This encapsulated power module can be used in a wide variety of applications, ranging from simple stand-alone operation to an integrated part of sophisticated power architecture. To maximum flexibility, internal fusing is not included; however, to achieve maximum safety and system protection, always use an input line fuse. The safety agencies require a normal-blow fuse with maximum rating of 3A for JFW24Sxx-xxxx modules and 1.5A for JFW48Sxx-xxxx modules. Based on the information provided in this data sheet on Inrush energy and maximum DC input current; the same type of fuse with lower rating can be used. Refer to the fuse manufacturer's data for further information.

MTBF and Reliability

The MTBF of the JFW Series of DC/DC converters has been calculated using Bellcore TR-NWT-000332 Case I: 50% stress, Operating Temperature at 40°C (Ground fixed and controlled environment). The resulting figure for MTBF is 1.322×10^6 hours.

MIL-HDBK 217F NOTICE2 FULL LOAD, operating Temperature at 25°C. The resulting figure for MTBF is 5.147×10^5 hours.

Ordering Information:

Part Number Example:

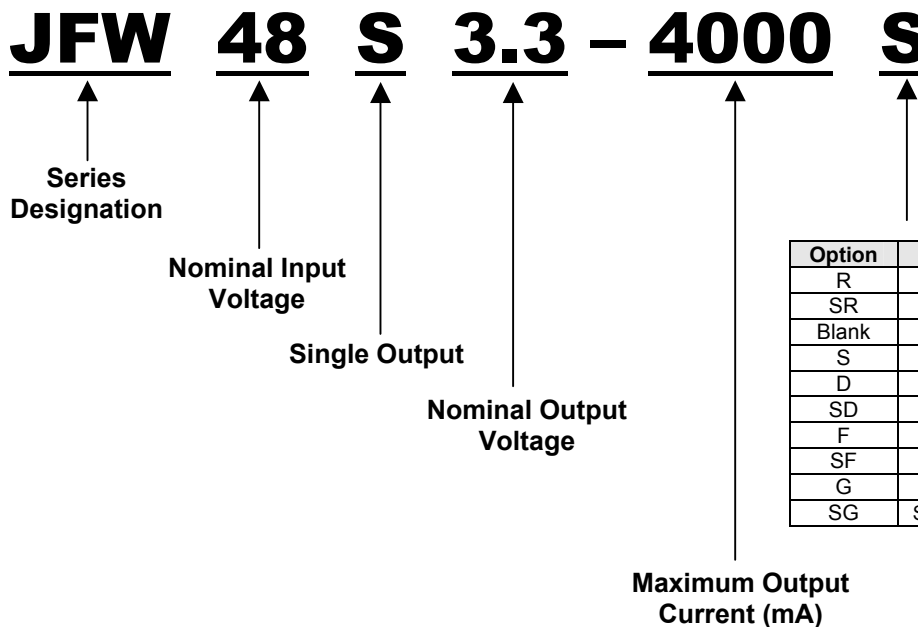

Option	Description
R	Negative Remote ON/OFF with DIP
SR	Negative Remote ON/OFF with SMT
Blank	Positive Remote ON/OFF with DIP
S	Positive Remote ON/OFF with SMT
D	DIP Type without ON/OFF pin
SD	SMT Type without ON/OFF pin
F	DIP Type without TRIM pin
SF	SMT Type without TRIM pin
G	DIP Type without ON/OFF & TRIM pin
SG	SMT Type without ON/OFF & TRIM pin

Company Information:

Wall Industries, Inc. has created custom and modified units for over 40 years. Our in-house research and development engineers will provide a solution that exceeds your performance requirements on-time and on budget. Our ISO9001-2000 certification is just one example of our commitment to producing a high quality, well documented product for our customers.

Our past projects demonstrate our commitment to you, our customer. Wall Industries, Inc. has a reputation for working closely with its customers to ensure each solution meets or exceeds form, fit and function requirements. We will continue to provide ongoing support for your project above and beyond the design and production phases. Give us a call today to discuss your future projects.

Contact **Wall Industries** for further information:

Phone: ☎ (603)778-2300
Toll Free: ☎ (888)587-9255
Fax: ☎ (603)778-9797
E-mail: sales@wallindustries.com
Web: www.wallindustries.com
Address: 5 Watson Brook Rd.
Exeter, NH 03833